

For BROTHER COMPACT MACHINING CENTER

SPEEDIO

CNC ROTARY TABLE & TOOL HOLDER

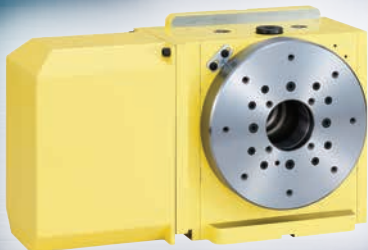

NCT200LSA-BR3

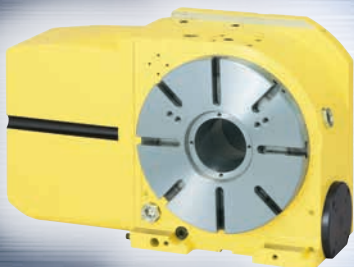

CNC260PLSA-BR3

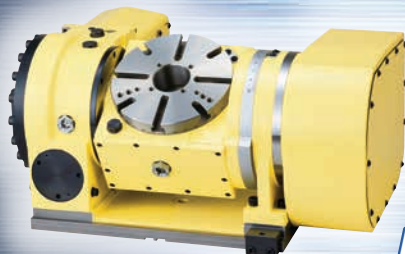

5AX-201SA-BR3



TOOLING



ANTI-WEARING, HIGH RIGIDITY and HIGH SPEED ROTATION

Worldwide Field-proven NIKKEN CNC Rotary Table



Worm Wheel

Specially hardened and furthermore ion-nitrided on the tooth. Thus, the problem of the sliding friction is solved. The hardness of the tooth surface and inside is shown at right hand side.

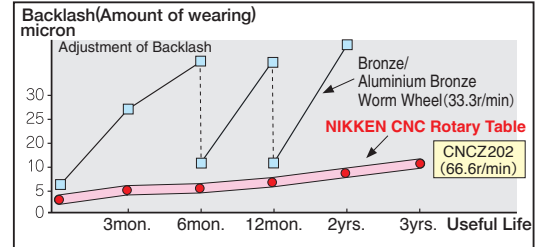
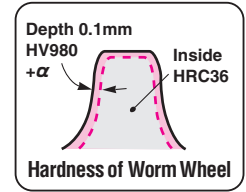

It is not exaggeration that the most important parts of the CNC rotary table is worm system. Please choose NIKKEN CNC rotary table with special worm system for our anti-wearing, high rigidity and high speed rotation.

CNC ROTARY TABLE for **SPEEDIO**



The servo motor and the amplifier of the rotary table for **SPEEDIO** are special one only for **SPEEDIO**.

The existing servo motors or the amplifiers for BROTHER TAPPING CENTER can not be used.

Please specify the machine name and the layout of the rotary table, when ordering. Standard layout of the rotary table is to install the left-handed rotary table on the left side of the machine.

SPEEDIO S300Xd2 ☞ P.3	CNC105LSA-BR3
	CNC180LSA-BR3, 202LSA-BR3
	NCT200ELSA-BR3, 200LSA-BR3
	CNC205LSA-BR3 (Trunnion)
	5AX-100SA-BR3
	DD250LS-50
SPEEDIO (S500Xd2 S700Xd2 ☞ P.6 W1000Xd2 ☞ P.11	NCT200ELSA-BR3, 200LSA-BR3
	CNC180LSA-BR3, 202LSA-BR3
	CNC260PLSA-BR3, 302PLSA-BR3
	5AX-130SA-BR3
	5AX-201SA-BR3
	CNC205LSA-BR3 (Trunnion)
DD250LS-50	

★It can also support high speed rotation Z series.

SPEEDIO R450Xd1*1 (With Pallet Changer) ☞ P.16	CNC105LSA-BR3
	CNC180LSA-BR3, 202LSA-BR3
	NCT200ELSA-BR3, 200LSA-BR3
	CNC205LSA-BR3 (Trunnion)
	5AX-130BASA-BR3
	CNC105LSA-BR3
SPEEDIO R650Xd1*2 (With Pallet Changer) ☞ P.19	CNC180LSA-BR3, 202LSA-BR3
	NCT200ELSA-BR3, 200LSA-BR3
	CNC205LSA-BR3 (Trunnion)
	5AX-130BASA-BR3
	5AX-2MT-105-120SA-BR3

Basically, 2sets are needed for pullee changer

Please specify the options

	R450Xd1		R650Xd1	
	Standard	Option	Standard	Option
Swing Dia.(mm)	1,020	1,100	1,250	1,300
JIG Height(mm)	300	380	350	450
Load (kg)	120	200	200	300

★Option can be selected independently.

CNC ROTARY TABLE wiring diagram for **SPEEDIO** NIKKEN

The amplifier, all cables and the rotary table with the suitable servo motor will be supplied from NIKKEN. Installation fee will be charged separately.

SPEEDIO Wiring Diagram (Additional 1 Axis)

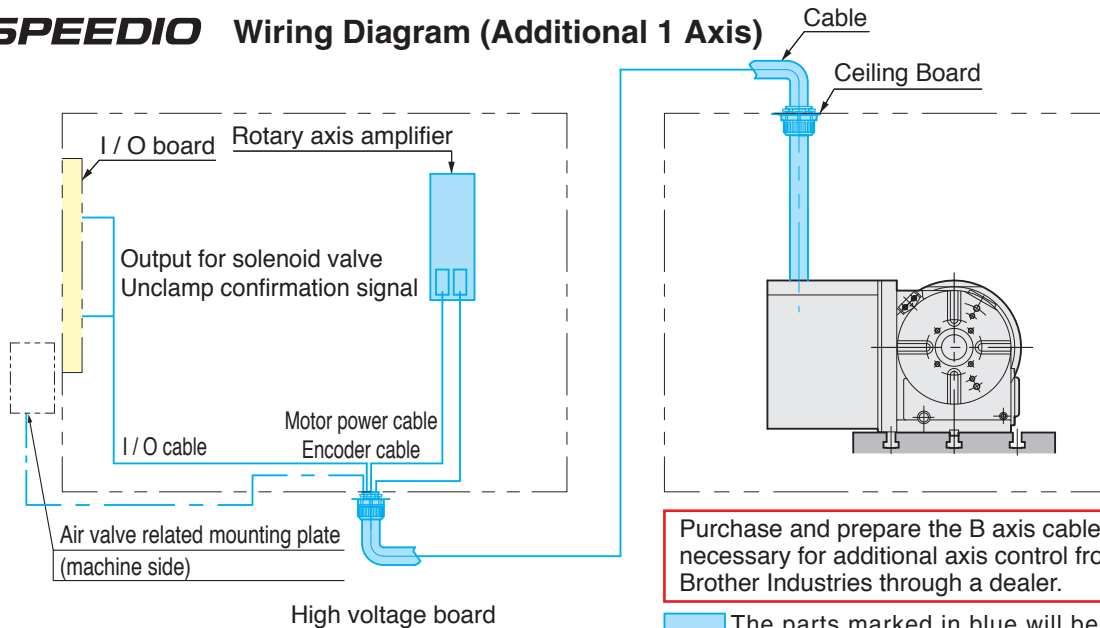

SPEEDIO Wiring Diagram (Additional 2 Axis)

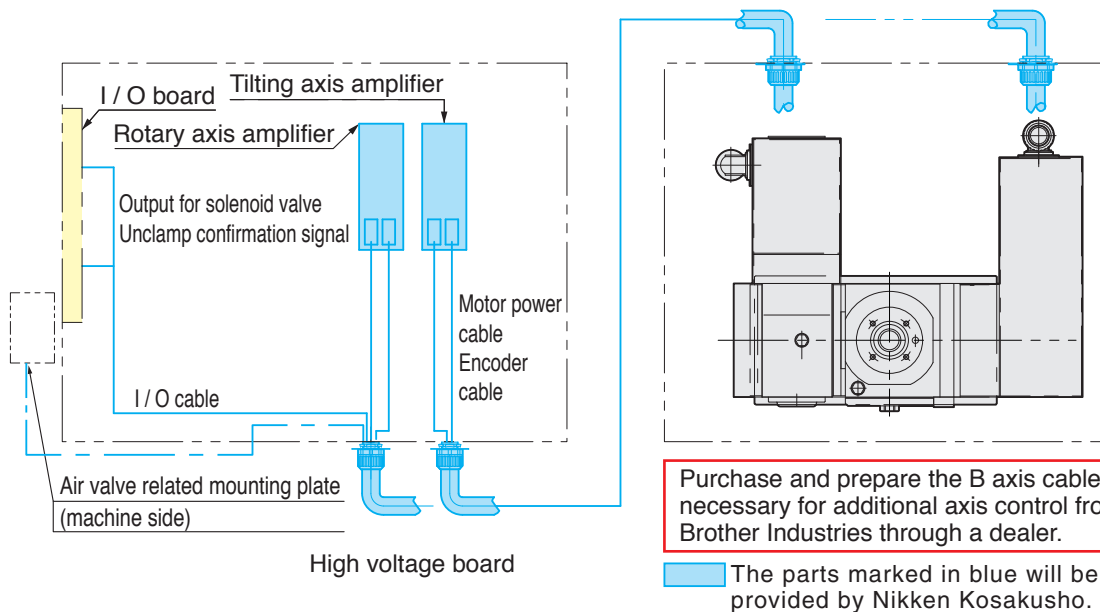

⚠ CAUTION

Please note below when using compact machining center **SPEEDIO** abroad.

- When exporting together CNC circular table or rotary inclination table of 1 axis additional axis control, export permission may be required from Ministry of Economy, Trade and Industry Please consult with the distributor.
- If a rotary tilting table is to be exported together with a machine, or if it is to be additionally installed after exporting overseas, an export license may be required by the Ministry of Economy, Trade and Industry, so please consult with the distributor.

S300Xd2

S500Xd2
S700Xd2

W1000Xd2

R450Xd1

R650Xd1

CONTROLLER

TOOL

CNC ROTARY TABLE for *SPEEDIO S300Xd2*



CNC105LSA-BR3

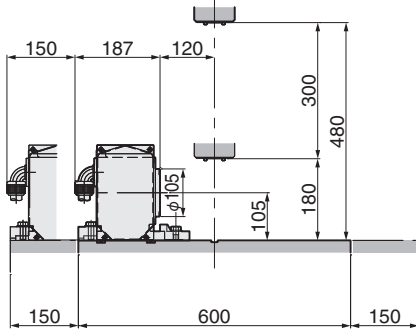
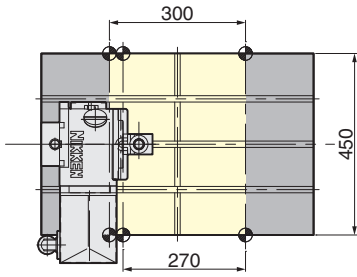

φ105mm type CNC ROTARY TABLE

- Diameter of Table :φ105mm
- MAX. Work Load :30kg
- MAX. Rotation Speed :33.3(r/min), **66.6(r/min)*1**
- Indexing Accuracy :±30sec.
- Brake Torque :205Nm
- Net Weight :30kg
- Servo Motor :R2AAB8100HXRG
- Spindle Hole :φ60mm_{H7}×φ30mm Through Hole

*1:High speed Z series

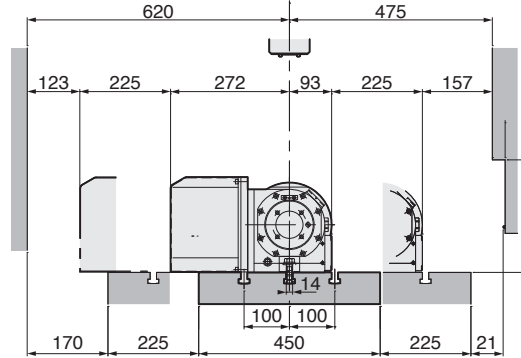

CNC180LSA-BR3

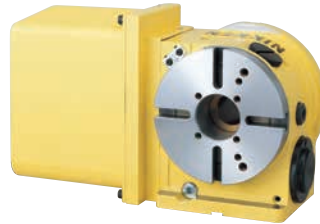
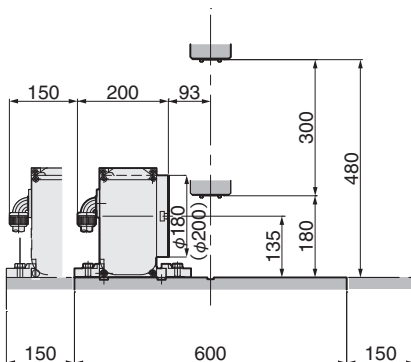
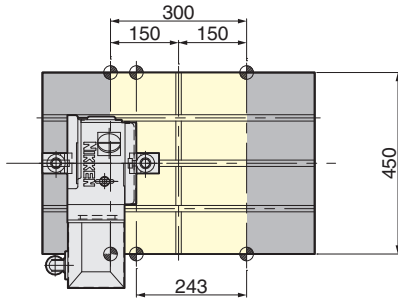

φ180mm type CNC ROTARY TABLE

- Diameter of Table :φ180mm
- MAX. Work Load :100kg (Vertical) 200kg (Horizontal)
- MAX. Rotation Speed :33.3(r/min), **66.6(r/min)*1**
- Indexing Accuracy :±20sec.
- Brake Torque :303Nm
- Net Weight :48kg
- Servo Motor :R2AAB8100HXRG
- Spindle Hole :φ60mm_{H7}×φ40mm Through Hole

*1:High speed Z series

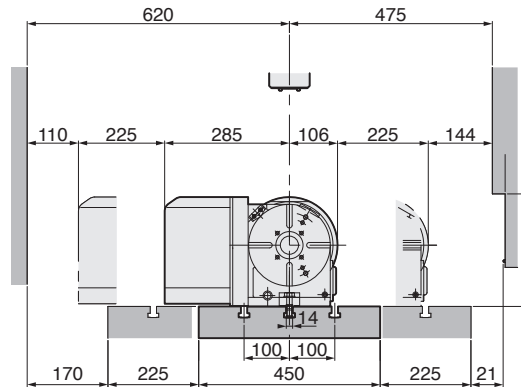

CNC105LSA-BR3

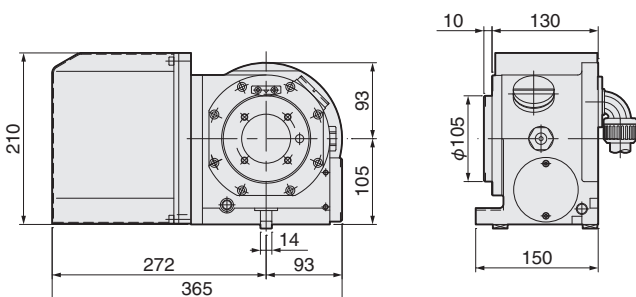

CNC180LSA-BR3 CNC202LSA-BR3 is also available

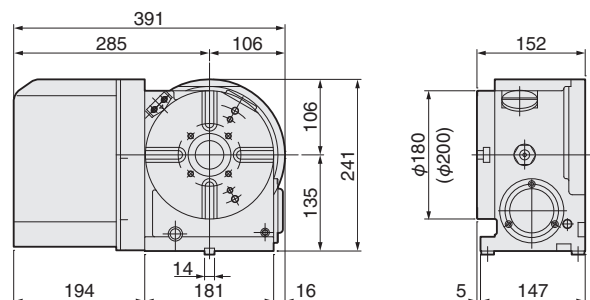

NCT ROTARY TABLE for *SPEEDIO S300Xd2*



S300Xd2

NCT200ELSA-BR3

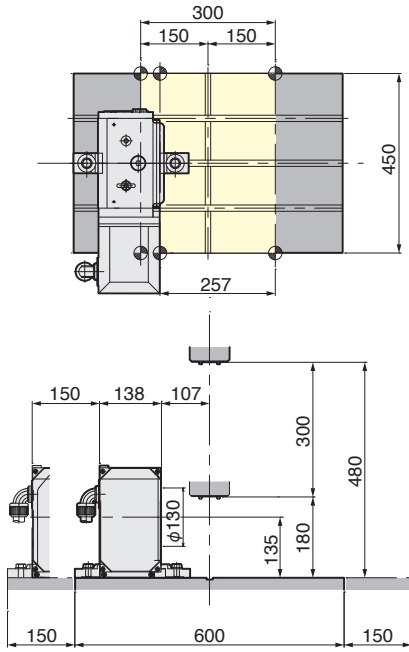

φ200mm type NCT ROTARY TABLE (Without φ200 face plate)

- Diameter of Table :φ130mm
 - MAX. Work Load :100kg (Vertical)200kg (Horizontal)
 - MAX. Rotation Speed :33.3 (r/min) ,**66.6 (r/min)***1
 - Indexing Accuracy :±20sec.
 - Brake Torque :900Nm
 - Net Weight :62kg
 - Servo Motor :R2AAB8100HXRG
 - Spindle Hole :φ60mm_{H7}×φ40mm Through Hole
- *1:High speed Z series

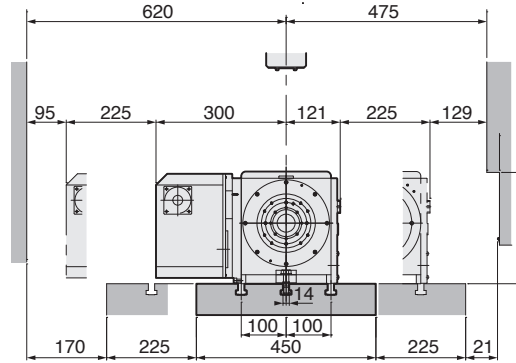

NCT200LSA-BR3

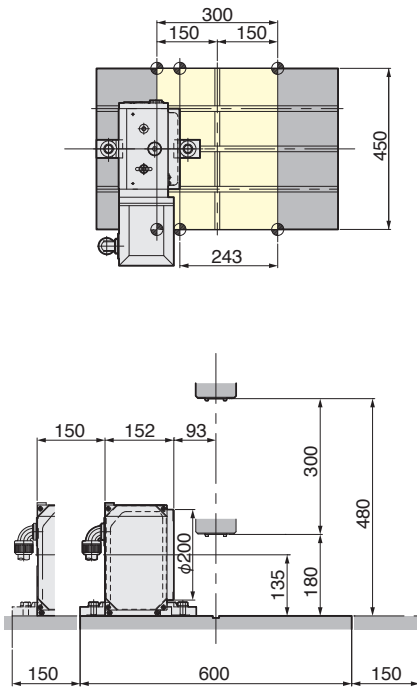

φ200mm type NCT ROTARY TABLE

- Diameter of Table :φ200mm
 - MAX. Work Load :100kg (Vertical)200kg (Horizontal)
 - MAX. Rotation Speed :33.3 (r/min) ,**66.6 (r/min)***1
 - Indexing Accuracy :±20sec.
 - Brake Torque :900Nm
 - Net Weight :65kg
 - Servo Motor :R2AAB8100HXRG
 - Spindle Hole :φ60mm_{H7}×φ40mm Through Hole
- *1:High speed Z series

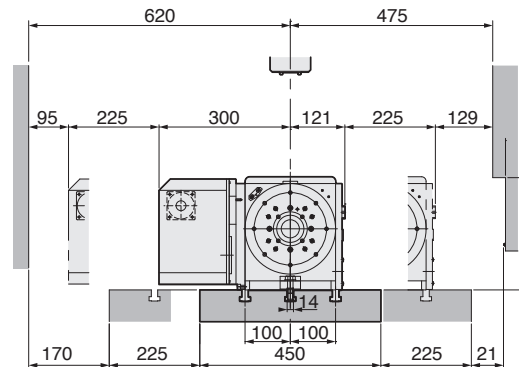

NCT200ELSA-BR3

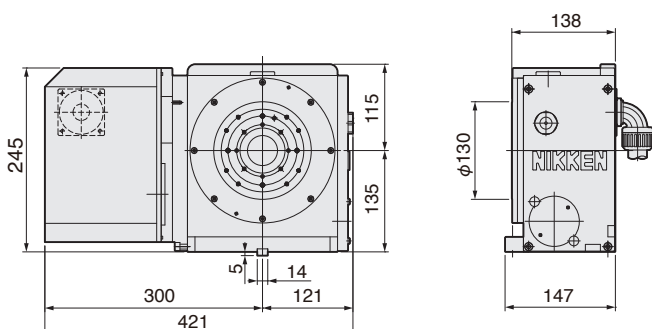

NCT200LSA-BR3

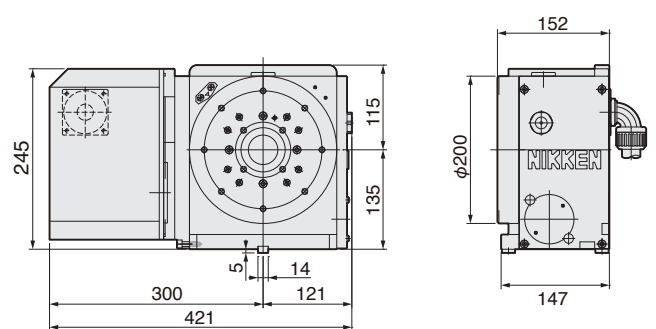

CNC ROTARY TABLE for *SPEEDIO S300Xd2*



CNC205LSA-BR3(CST100-135) Trunnion type Table

S300Xd2

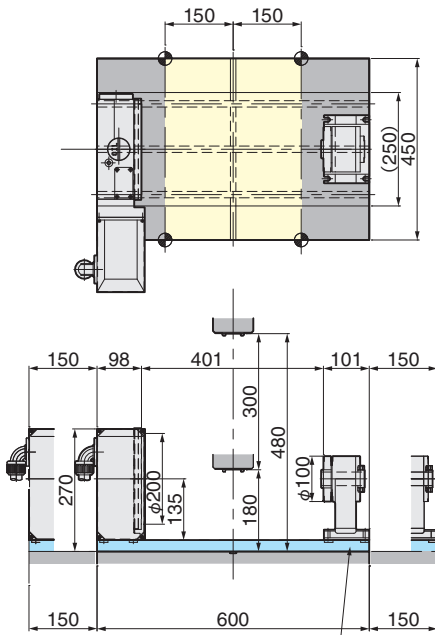

φ200mm Slim type CNC ROTARY TABLE

- Diameter of Table :φ200mm
- MAX. Work Load :100kg (with support table)
- MAX. Rotation Speed :33.3 (r/min), **66.6 (r/min)*1**
- Indexing Accuracy :±20sec.
- Brake Torque :380Nm
- Net Weight :45kg
- Servo Motor :R2AAB8100HXPRGA
- 6 ports built rotary joint can be fitted

*1:High speed Z series

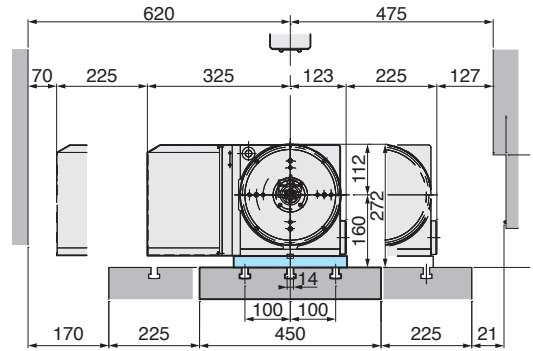

NIKKEN doesn't provide the plate

5AX-100SA-BR3

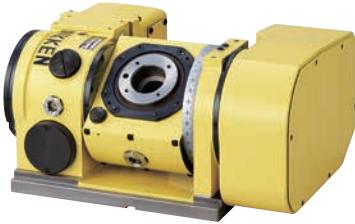

φ100mm Compact type 5AX- TILTING ROTARY TABLE

- Diameter of Table :φ90mm
- MAX. Work Load :20kg (Vertical) 40kg (Horizontal)
- MAX. Rotation Speed :44.4 (r/min) (Rotary), 22.2 (r/min) (Tilting)
- Indexing Accuracy :±30sec. (Rotary), 60sec. (Tilting)
- Brake Torque :205Nm (Rotary), 600Nm (Tilting)
- Net Weight :84kg
- Servo Motor :R2AD08040FXR5E (Rotary)
R2AD08040FXR5E (Tilting)
- Spindle Hole :φ50mm_{H7}×φ30mm Through Hole
- Tilting Angle :0°~105°

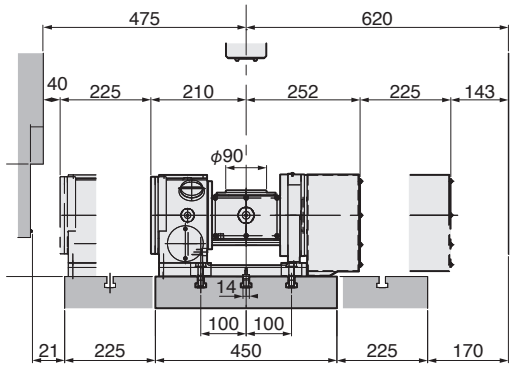
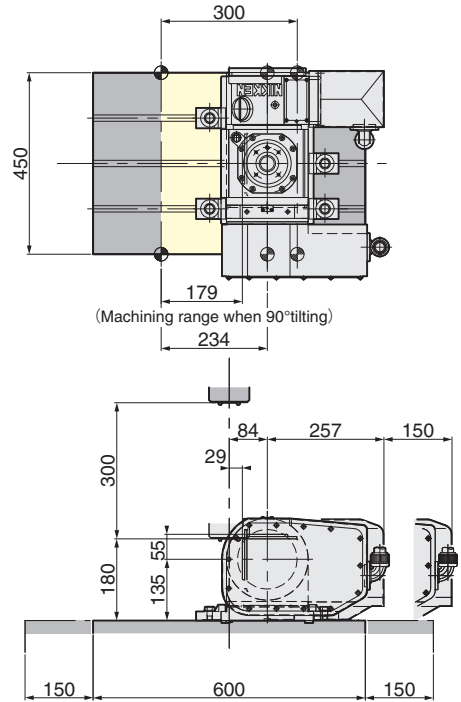

CNC205LSA-BR3

CST100-135

5AX-100SA-BR3

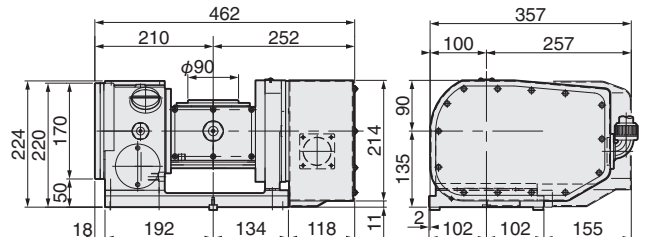
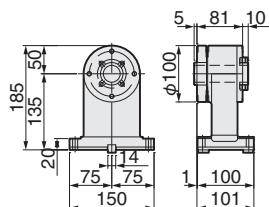
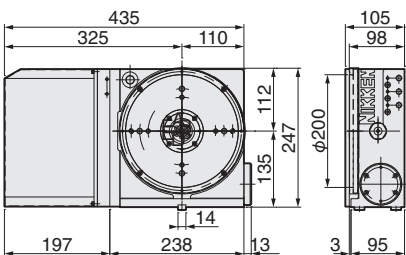

NCT ROTARY TABLE for SPEEDIO S500Xd2/S700Xd2 **NIKKEN**

NCT200ELSA-BR3

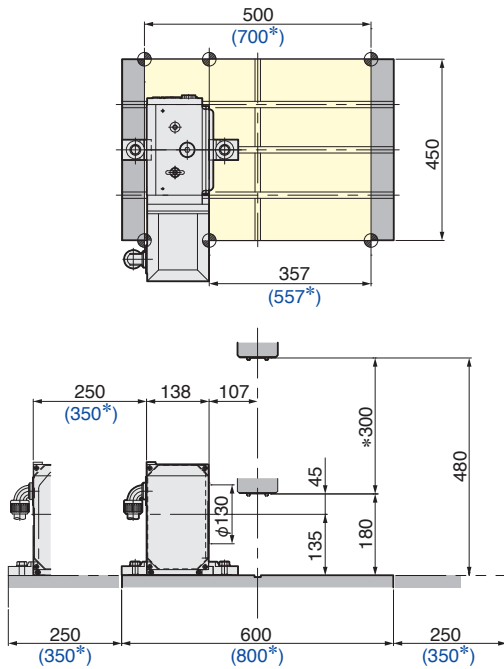

φ200mm type NCT ROTARY TABLE (Without φ200 faceplate)

- Diameter of Table :φ130mm
 - MAX. Work Load :100kg (Vertical)200kg (Horizontal)
 - MAX. Rotation Speed :33.3 (r/min), **66.6 (r/min)***1
 - Indexing Accuracy :±20sec.
 - Brake Torque :900Nm
 - Net Weight :62kg
 - Servo Motor :R2AAB8100HXRGA
 - Spindle Hole :φ60mm_{H7}×φ40mm Through Hole
- *1:High speed Z series

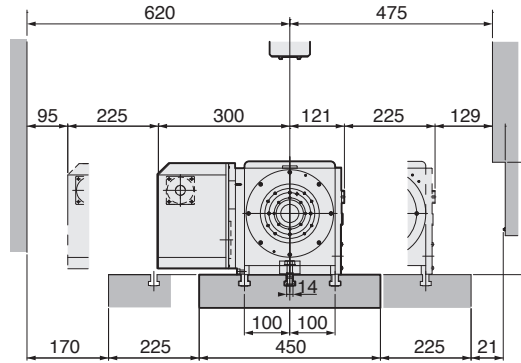

(*)The figures with blue color are the figures for S700Xd2.

*Z-axis stroke of 380 mm is also available.

NCT200LSA-BR3

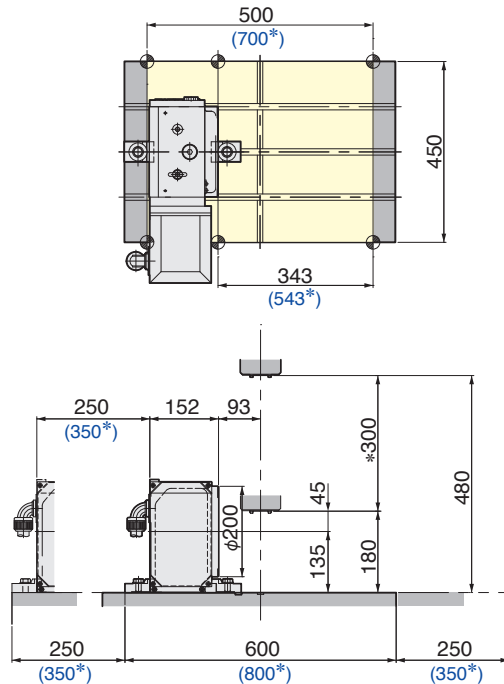

φ200mm type NCT ROTARY TABLE

- Diameter of Table :φ200mm
 - MAX. Work Load :100kg (Vertical)200kg (Horizontal)
 - MAX. Rotation Speed :33.3 (r/min), **66.6 (r/min)***1
 - Indexing Accuracy :±20sec.
 - Brake Torque :900Nm
 - Net Weight :65kg
 - Servo Motor :R2AAB8100HXRGA
 - Spindle Hole :φ60mm_{H7}×φ40mm Through Hole
- *1:High speed Z series

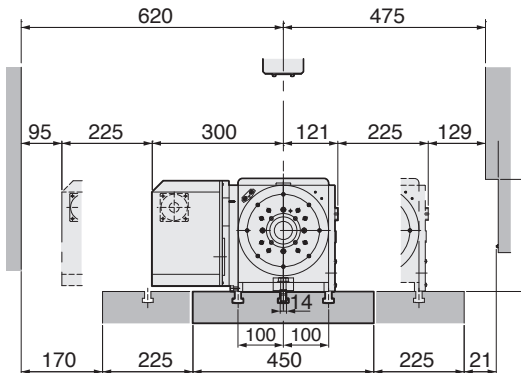

(*)The figures with blue color are the figures for S700Xd2.

*Z-axis stroke of 380 mm is also available.

NCT200ELSA-BR3

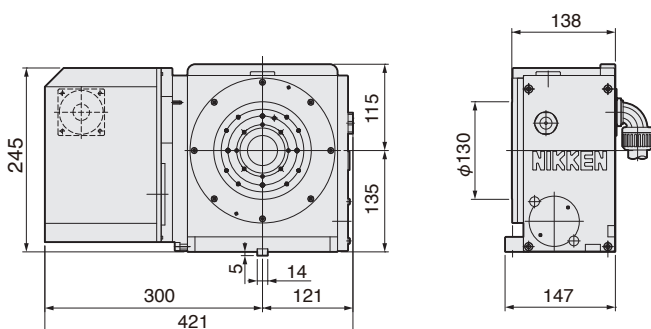

NCT200LSA-BR3

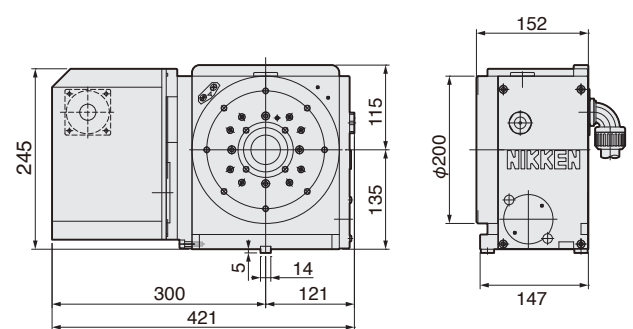

CNC ROTARY TABLE for SPEEDIO S500Xd2/S700Xd2 **NIKKEN**

CNC180LSA-BR3

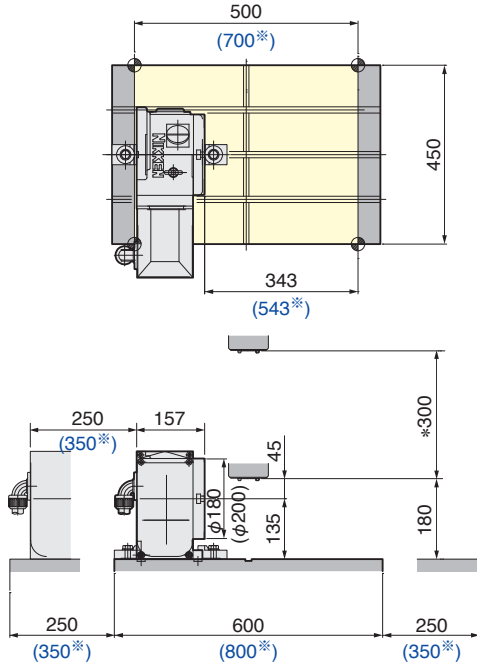

φ180mm type CNC ROTARY TABLE

- Diameter of Table :φ180mm
- MAX. Work Load :100kg (Vertical) 200kg (Horizontal)
- MAX. Rotation Speed :33.3 (r/min) ,66.6 (r/min)*1
- Indexing Accuracy :±20sec.
- Brake Torque :303Nm
- Net Weight :48kg
- Servo Motor :R2AAB8100HXRGA
- Spindle Hole :φ60mmH7×φ40mm Through Hole

*1:High speed Z series

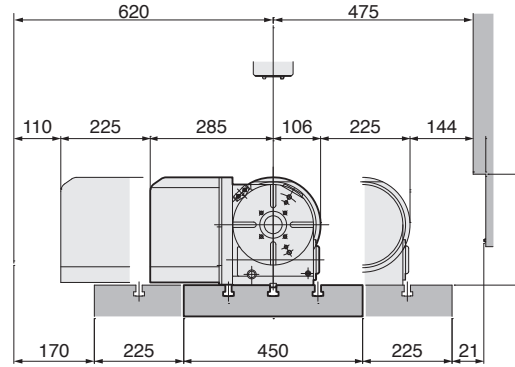

(*)The figures with blue color are the figures for S700Xd2.

*Z-axis stroke of 380 mm is also available.

CNC260PLSA-BR3

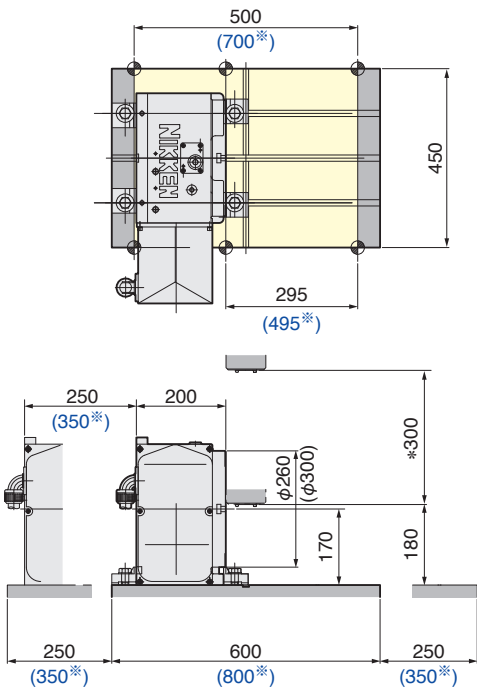

NEW

φ260mm type CNC ROTARY TABLE

- Diameter of Table :φ260mm
- MAX. Work Load :300kg (Vertical) 150kg (Horizontal)
- MAX. Rotation Speed :25 (r/min) ,50 (r/min)*1
- Indexing Accuracy :±20sec.
- Brake Torque :1430Nm (Pneumatic)
- Net Weight :115kg
- Servo Motor :R2AAB8100HXRGA
- Spindle Hole :φ80mmH7 Through Hole

*1:High speed Z series

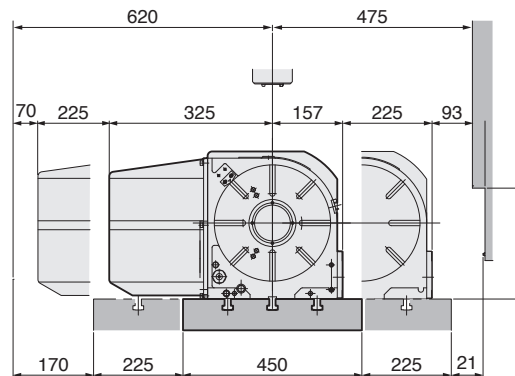

(*)The figures with blue color are the figures for S700Xd2.

*Z-axis stroke of 380 mm is also available.

CNC180LSA-BR3 CNC202LSA-BR3 is also available.

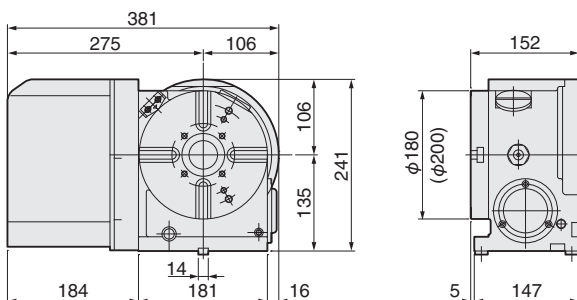

CNC260LSA-BR3 CNC302LSA-BR3 is also available.

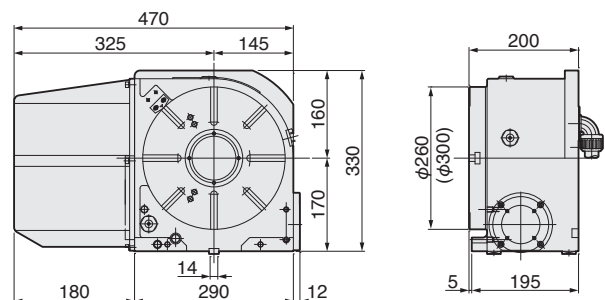

CNC ROTARY TABLE for SPEEDIO S500Xd2/S700Xd2 **NIKKEN**

5AX-130SA-BR3

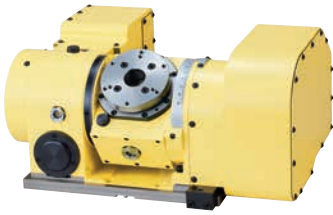

φ130mm type 5AX- TILTING ROTARY TABLE

- Diameter of Table :φ105mm(With φ130mm sub table)
- MAX. Work Load :25kg (Vertical)50kg (Horizontal)
- MAX. Rotation Speed :22.2(r/min) (Rotary), 11.1(r/min) (Tilting)
- Indexing Accuracy :±30sec. (Rotary), 60sec. (Tilting)
- Brake Torque :205Nm (Rotary), 303Nm (Tilting)
- Net Weight :115kg
- Servo Motor :R2AAB8100HXRGA (Rotary)
R2AAB8100HXRGA (Tilting)
- Spindle Hole :φ60mm_{H7}×φ30mm Through Hole
- Tilting Angle :0°~105°

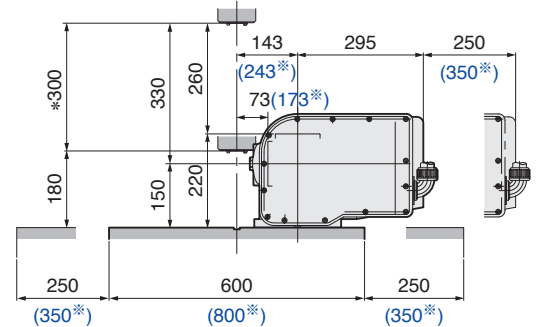
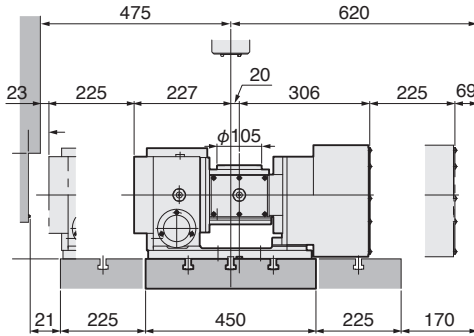
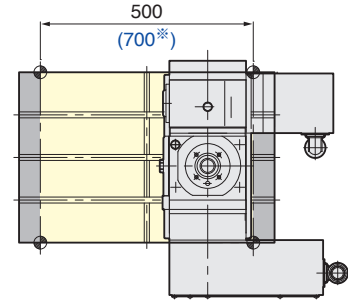

(*)The figures with blue color are the figures for S700Xd2.

*Z-axis stroke of 380 mm is also available.

5AX-201SA-BR3

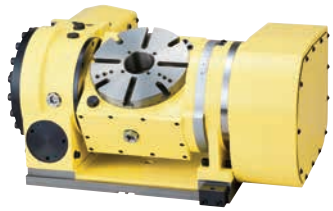

φ200mm type 5AX- TILTING ROTARY TABLE

- Diameter of Table :φ200mm
- MAX. Work Load :40kg (Vertical)60kg (Horizontal)
- MAX. Rotation Speed :22.2(r/min) (Rotary), 16.6(r/min) (Tilting)
- Indexing Accuracy :±15sec. (Rotary), 60sec. (Tilting)
- Brake Torque :588Nm (Rotary), 608Nm (Tilting) (Hydraulic)
303Nm (Rotary), 303Nm (Tilting) (Pneumatic)
- Net Weight :160kg
- Servo Motor :R2AAB8100HXRGA (Rotary)
R2AAB8100HXRGA (Tilting)
- Spindle Hole :φ60mm_{H7}×φ50mm Through Hole
- Tilting Angle :0°~105°

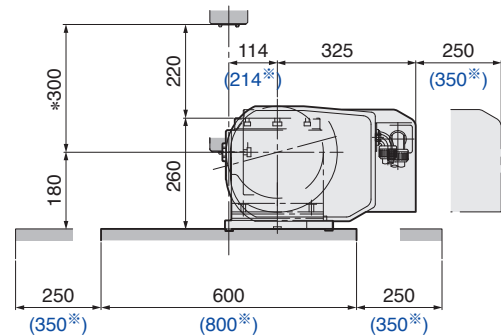
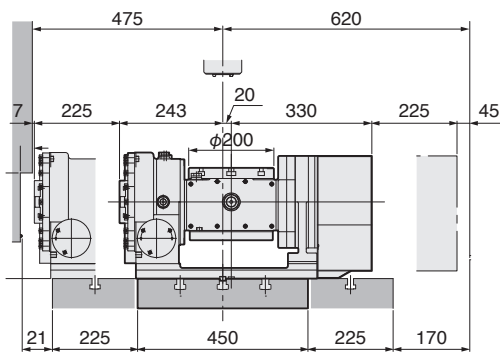
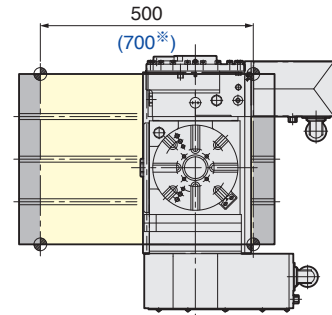

(*)The figures with blue color are the figures for S700Xd2.

*Z-axis stroke of 380 mm is also available.

5AX-130SA-BR3

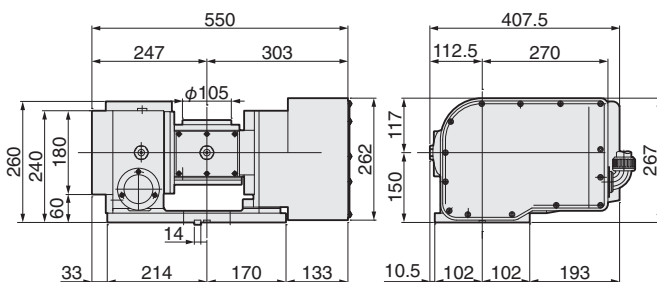

5AX-201SA-BR3

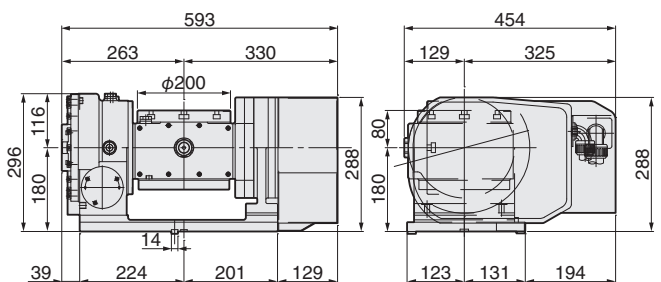

CNC ROTARY TABLE for SPEEDIO S500Xd2/S700Xd2 **NIKKEN**

CNC205LSA-BR3(TAT-105N-135)

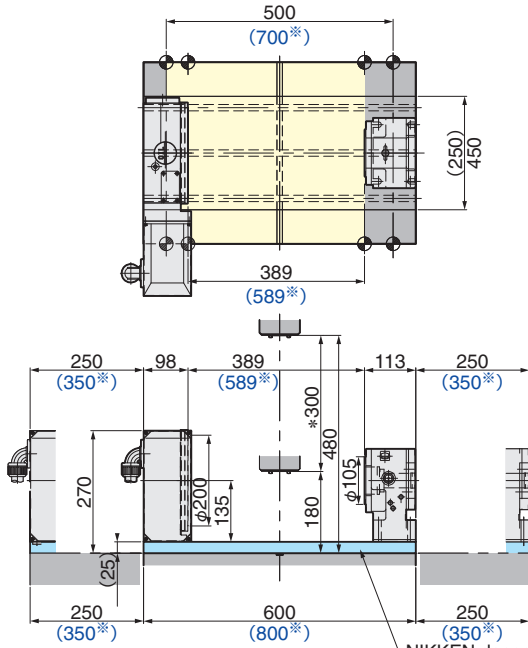

φ200mm Slim type CNC ROTARY TABLE

- Diameter of Table :φ200mm
- MAX. Work Load :100kg (with supprt table)
- MAX. Rotation Speed :33.3 (r/min), 66.6 (r/min)*1
- Indexing Accuracy :±20sec.
- Brake Torque :380Nm
- Net Weight :45kg
- Servo Motor :R2AAB8100HXRG
- 6 ports buit rotary joint can be fitted

*1:High speed Z series

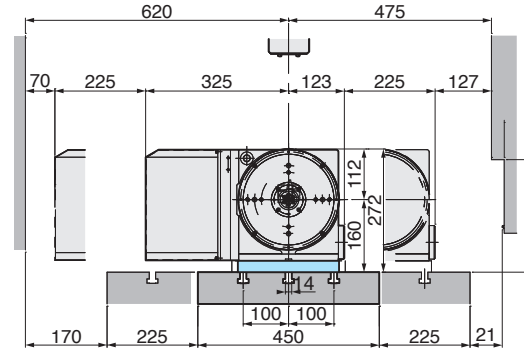

NIKKEN doesn't provide the plate

(*)The figures with blue color are the figures for S700Xd2.

*Z-axis stroke of 380 mm is also available.

CNC205LSA-BR3

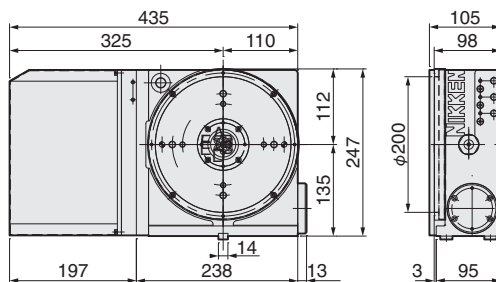

TAT-105N-135

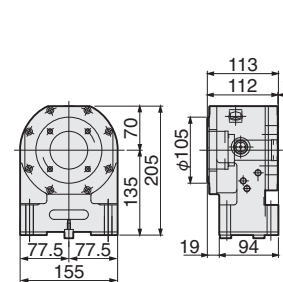

CNC ROTARY TABLE & SUPPORT TABLE with JIG FIXTURE **NIKKEN**



CNC180L (with 6+1 port Rotary joint) & TAT-105N-135

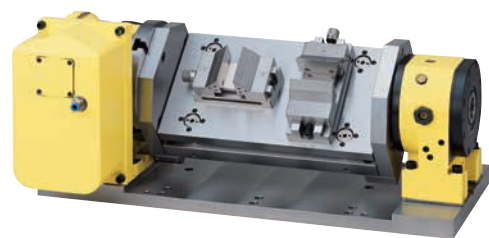

CNC180L & TAT-105N-135 (Precision stock vice)

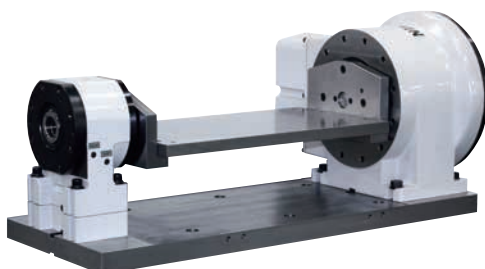

DD250LS-50 & TAT-105N-135



CNC205L & Support table (with power chuck)

ROTARY TABLE with DD MOTOR for SPEEDIO S500Xd2/S700Xd2



DD250LS-50

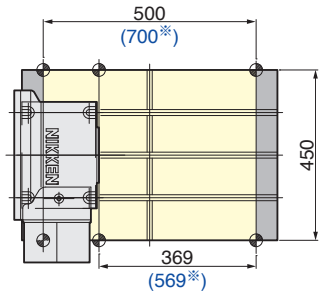

*The color of DD250LS-50 is white as standard.

φ250mm ROTARY TABLE with DD MOTOR

- Diameter of Table : φ250mm (φ250mm sub table: Option)
- Spindle External Diameter : φ130mm
- MAX. Rotation Speed : 200r/min
- Indexing Accuracy : 15sec.
- Brake Torque : 500Nm
- Net Weight : 75kg
- Servo Motor : DB23A053021W00
- Constant Torque : 50Nm
- MAX. Torque : 200Nm
- Spindle Hole : φ53mm_{H7} Through Hole

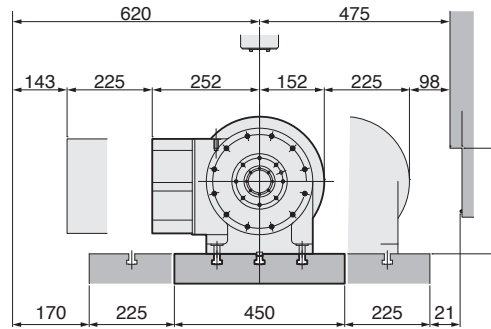
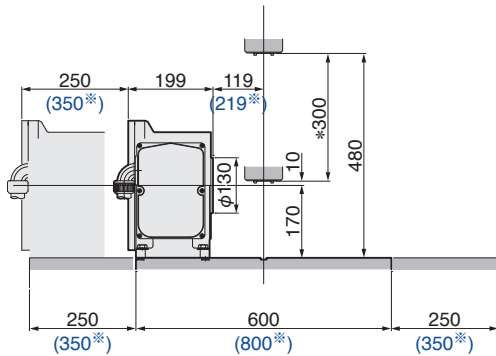

(*) The figures with blue color are the figures for S700Xd2.

*Z-axis stroke of 380 mm is also available.

DD250LS-50

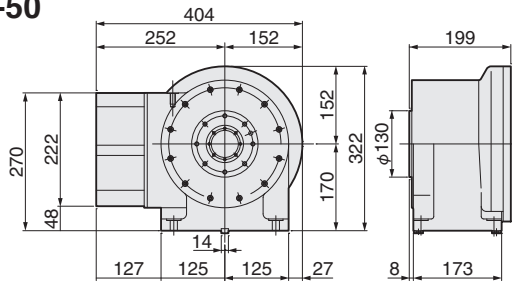

Notes on the Use of DD TABLES



DD table characteristics

- The spindle is linked directly to the motor for excellent responsiveness. As a tradeoff for this responsiveness, the system is very sensitive to external force and loads, so it is necessary to set suitable parameters for each application.
- Adjustment is necessary to perform 5-axis simultaneous machining (synchronized machining). The NIKKEN standard parameters can be used for indexing and positioning. After confirming that optional functions* for synchronized machining are available, it is necessary to make appropriate settings to satisfy the customer's machining time and machining precision requirements. For simultaneous operation, suitable settings must be made to align the 4th (5th) axis with the three basic axes (XYZ).

Clamping operation

Due to the characteristics of the DD table it can be turned easily by hand if power is not being supplied (free run state). The table will again be in the free run state when the servo turns off after the brake is applied, unless appropriate settings are made, and this can cause positioning inaccuracy.

Difference in structure between Direct Drive and Worm gear system

Direct drive table

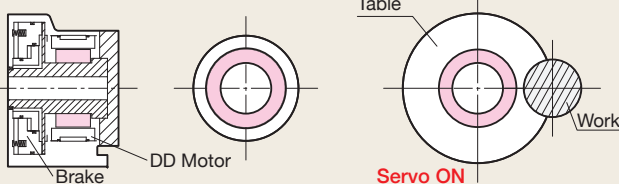

If the servo switches from on to off when in the unclamped state, no force holds the table in position and it can free fall from its own weight.

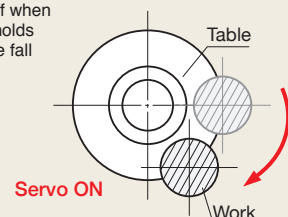

Worm gear table

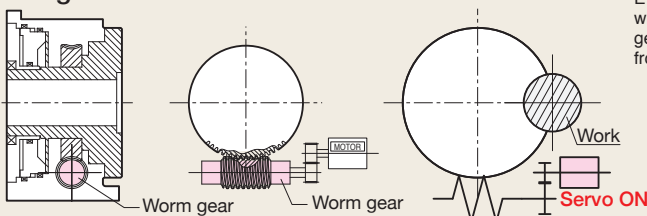

Even if the servo switches from on to off when in the unclamped state, the worm gear is engaged and prevents the table from moving (self-lock).

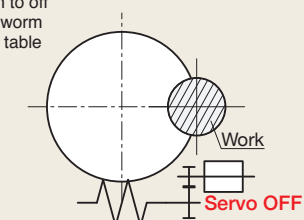

S500Xd2
S700Xd2

NCT ROTARY TABLE for *SPEEDIO W1000Xd2*



NCT200LSA-BR3

φ200mm type NCT ROTARY TABLE (Without φ200 faceplate)

- Diameter of Table :φ130mm
- MAX. Work Load :100kg (Vertical) 200kg (Horizontal)
- MAX. Rotation Speed :33.3 (r/min) ,**66.6 (r/min)***1
- Indexing Accuracy :±20sec.
- Brake Torque :900Nm
- Net Weight :62kg
- Servo Motor :R2AAB8100HXRGA
- Spindle Hole :φ60mm_{H7}×φ40mm Through Hole

*1:High speed Z series

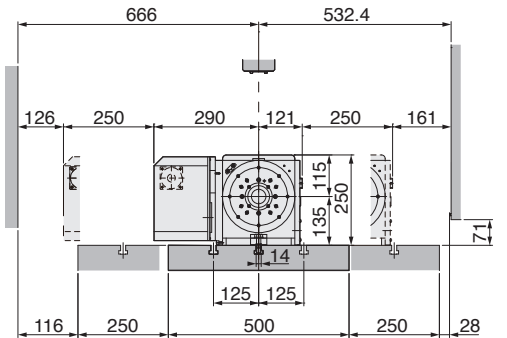
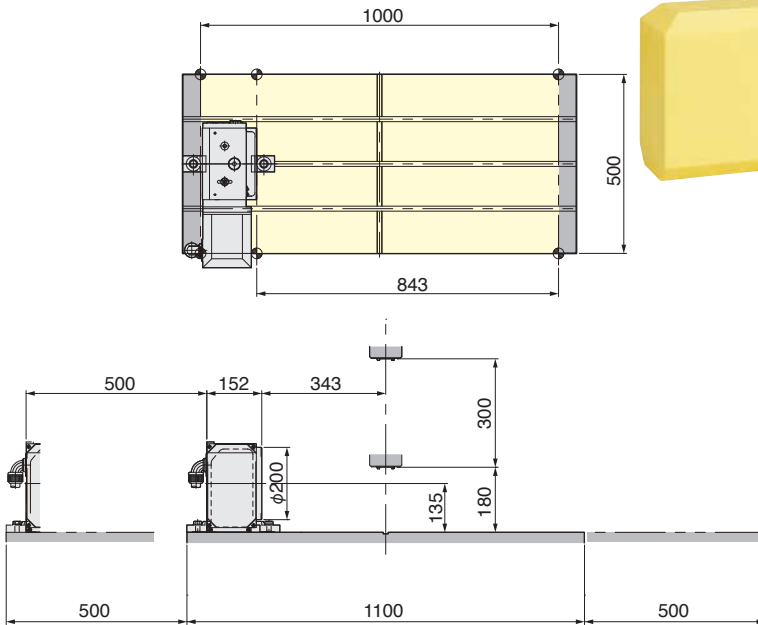

NCT200LSA-BR3 (TAT-105N-135)

φ200mm type NCT ROTARY TABLE

- Diameter of Table :φ200mm
- MAX. Work Load :100kg (Vertical) 200kg (Horizontal)
- MAX. Rotation Speed :33.3 (r/min) ,**66.6 (r/min)***1
- Indexing Accuracy :±20sec.
- Brake Torque :900Nm
- Net Weight :65kg
- Servo Motor :R2AAB8100HXRGA
- Spindle Hole :φ60mm_{H7}×φ40mm Through Hole

*1:High speed Z series

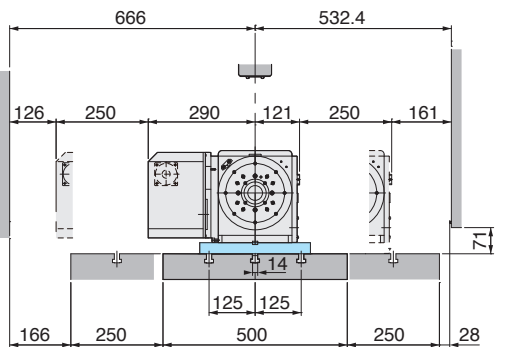
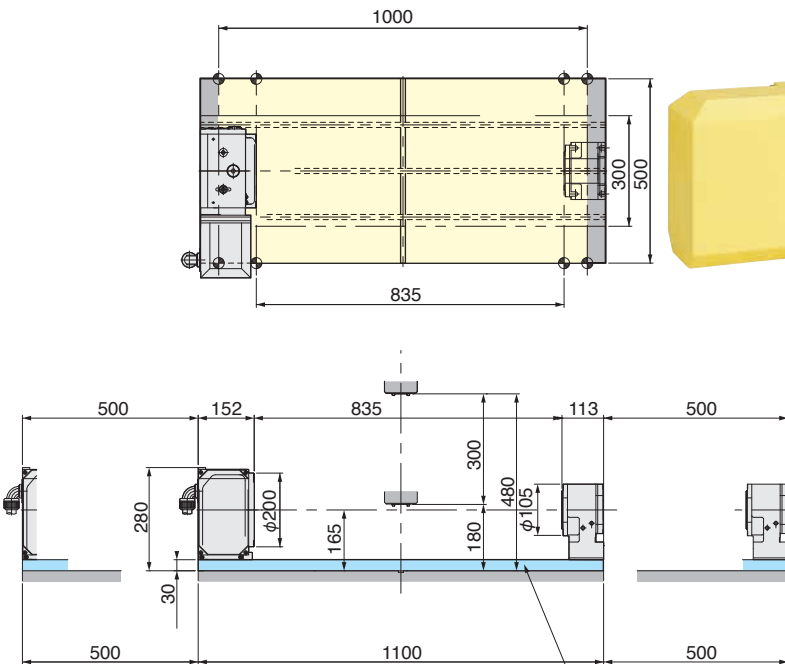

NIKKEN doesn't provide the plate

NCT200LSA-BR3

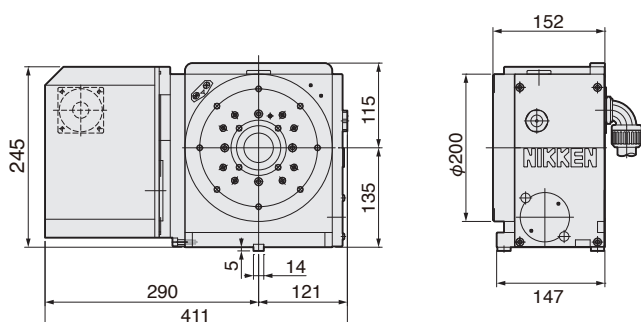

TAT-105N-135

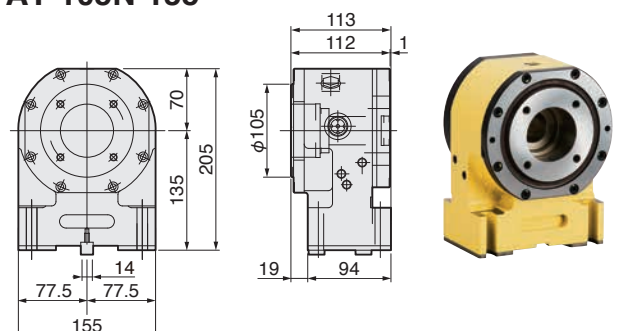

CNC ROTARY TABLE for SPEEDIO W1000Xd2



CNC180LSA-BR3

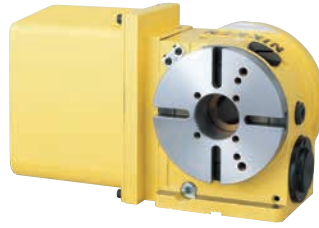
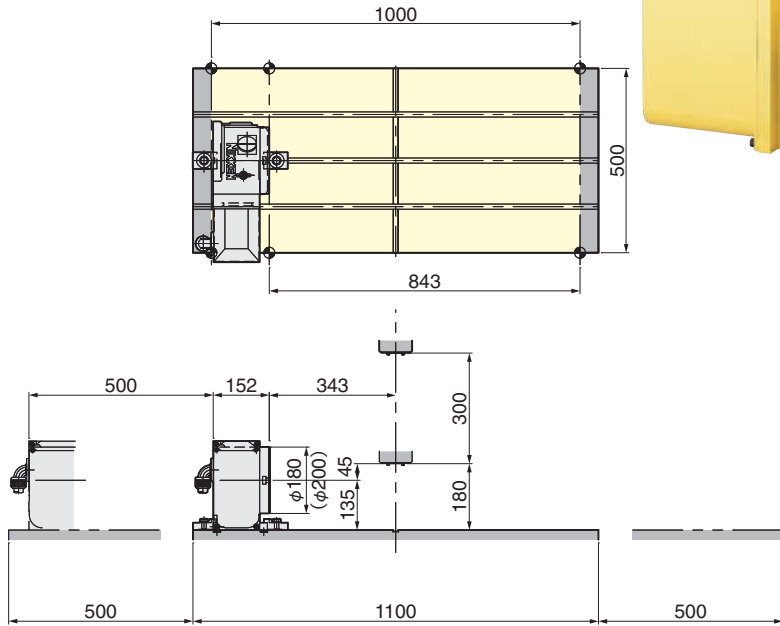

φ180mm type CNC ROTARY TABLE

- Diameter of Table :φ180mm (φ200mm)
 - MAX. Work Load :100kg (Vertical) 200kg (Horizontal)
 - MAX. Rotation Speed :33.3 (r/min) ,66.6 (r/min)*1
 - Indexing Accuracy :±20sec.
 - Brake Torque :303Nm
 - Net Weight :48kg
 - Servo Motor :R2AAB8100HXRGA
 - Spindle Hole :φ60mmH7×φ40mm Through Hole
- *1:High speed Z series

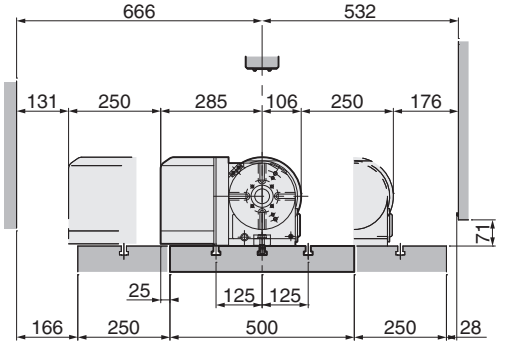

W1000Xd2

CNC180LSA-BR3 (TAT-105N-135)

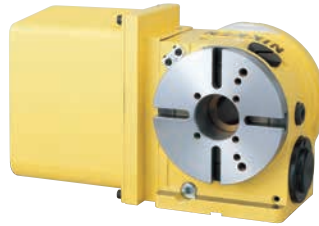
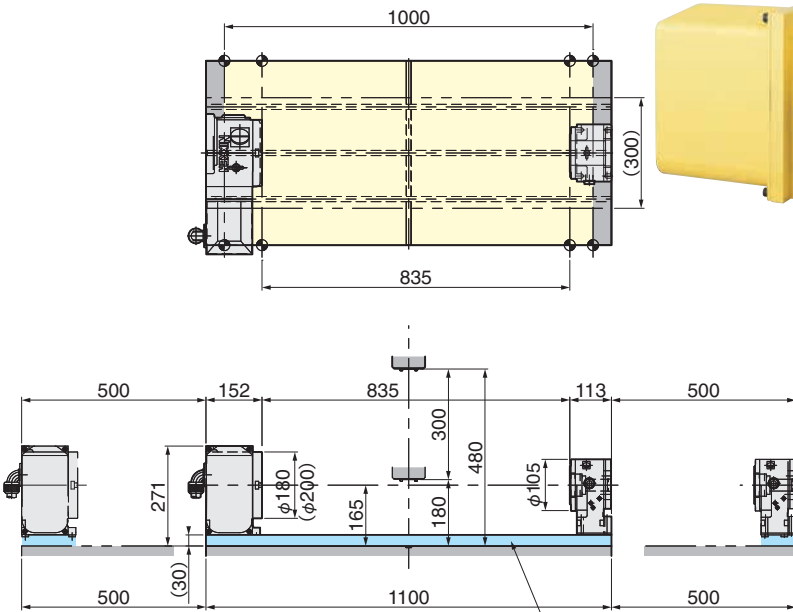

φ180mm type CNC ROTARY TABLE

- Diameter of Table :φ180mm (φ200mm)
 - MAX. Work Load :100kg (Vertical) 200kg (Horizontal)
 - MAX. Rotation Speed :33.3 (r/min) ,66.6 (r/min)*1
 - Indexing Accuracy :±20sec.
 - Brake Torque :303Nm
 - Net Weight :48kg
 - Servo Motor :R2AAB8100HXRGA
 - Spindle Hole :φ60mmH7×φ40mm Through Hole
- *1:High speed Z series

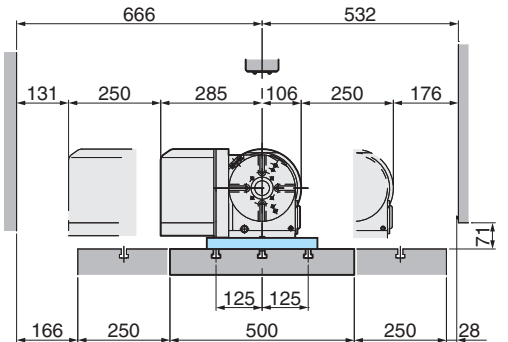

NIKKEN doesn't provide the plate

CNC180LSA-BR3 CNC202LSA-BR3 is also available

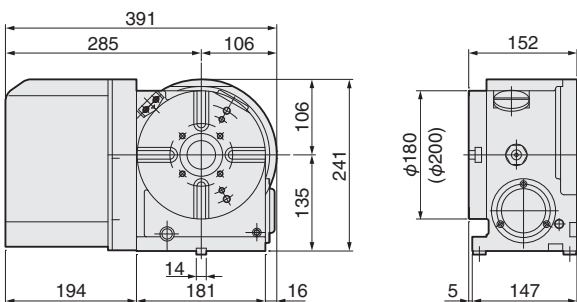

TAT-105N-135

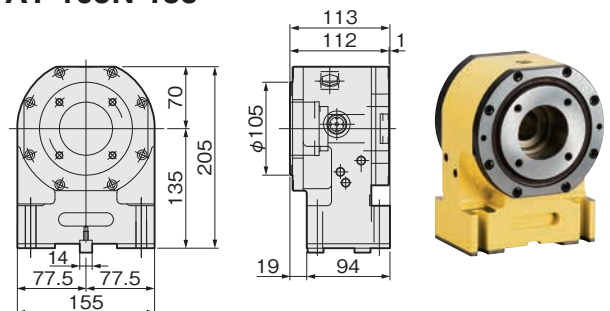

CNC ROTARY TABLE for *SPEEDIO W1000Xd2*



CNC260PLSA-BR3

NEW

φ260mm type CNC ROTARY TABLE

- Diameter of Table :φ260mm (φ300mm)
- MAX. Work Load :150kg (Vertical) 300kg (Horizontal)
- MAX. Rotation Speed :25 (r/min) ,50 (r/min)*1
- Indexing Accuracy :±20sec.
- Brake Torque :1430Nm (Pneumatic)
- Net Weight :120kg
- Servo Motor :R2AAB8100HXRGA
- Spindle Hole :φ80mm_{H7} Through Hole

*1:High speed Z series

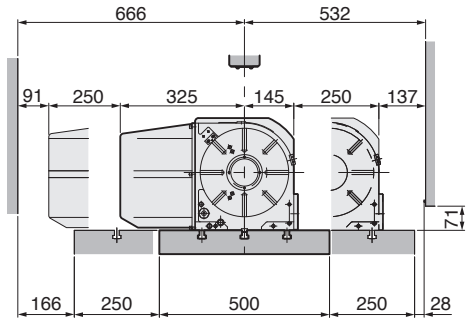
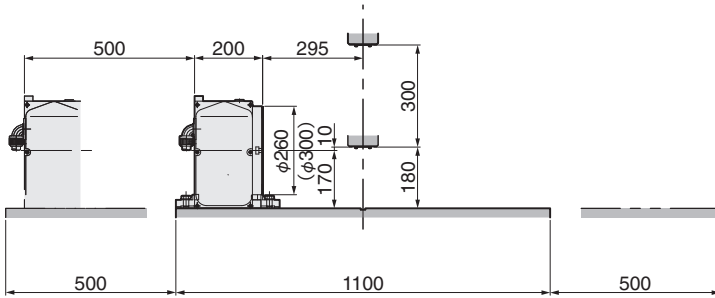
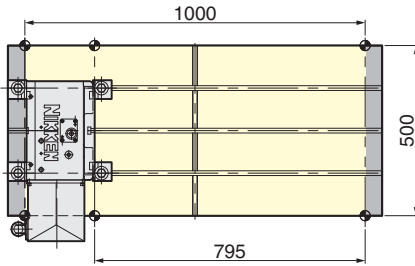
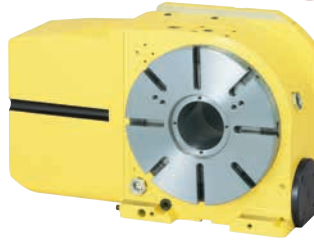

CNC260PLSA-BR3 (TAT-250N)

NEW

φ260mm type CNC ROTARY TABLE

- Diameter of Table :φ260mm (φ300mm)
- MAX. Work Load :150kg (Vertical) 300kg (Horizontal)
- MAX. Rotation Speed :25 (r/min) ,50 (r/min)*1
- Indexing Accuracy :±20sec.
- Brake Torque :1430Nm (Pneumatic)
- Net Weight :120kg
- Servo Motor :R2AAB8100HXRGA
- Spindle Hole :φ80mm_{H7} Through Hole

*1:High speed Z series

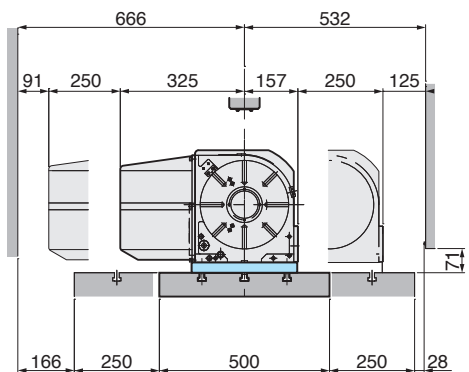
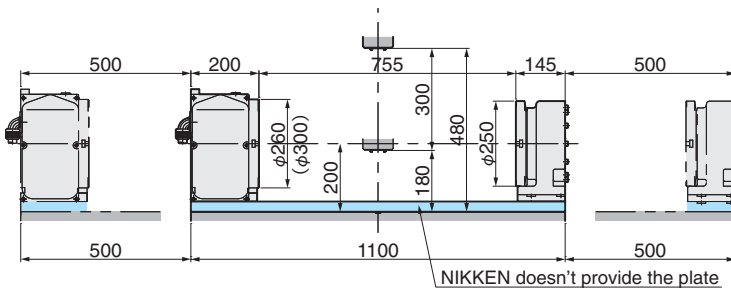
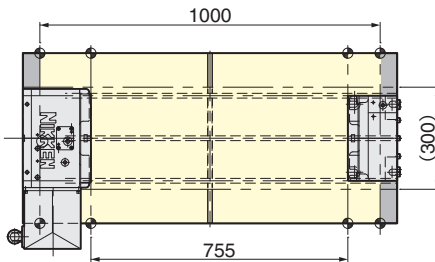

CNC260PLSA-BR3 CNC302PLSA-BR3 is also available.

TAT-250N

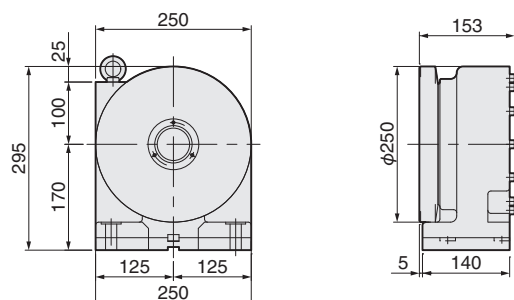
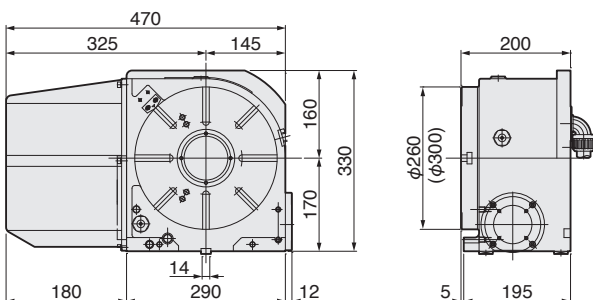

CNC ROTARY TABLE for *SPEEDIO* W1000Xd2



5AX-130SA-BR3



φ130mm type 5AX- TILTING ROTARY TABLE

- Diameter of Table :φ105mm (With φ130mm sub table)
- MAX. Work Load :25kg (Vertical) 50kg (Horizontal)
- MAX. Rotation Speed :22.2 (r/min) (Rotary), 11.1 (r/min) (Tilting)
- Indexing Accuracy :±30sec. (Rotary), 60sec. (Tilting)
- Brake Torque :205Nm (Rotary), 303Nm (Tilting)
- Net Weight :115kg
- Servo Motor :R2AAB8100HXRGA (Rotary)
R2AAB8100HXRGA (Tilting)
- Spindle Hole :φ60mm_{H7}×φ30mm Through Hole
- Tilting Angle :0°~105°

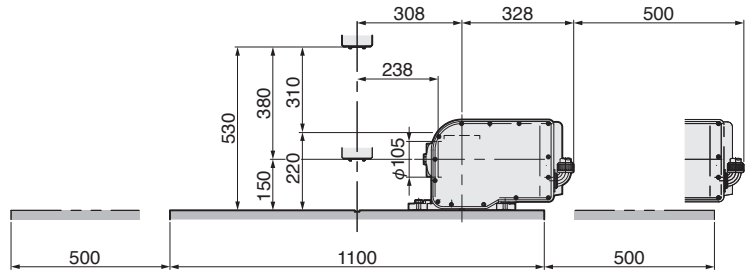
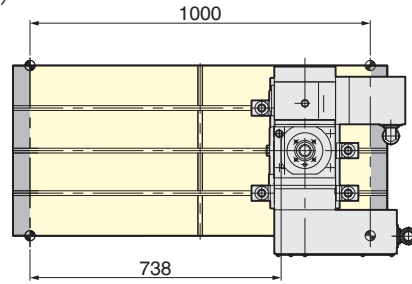
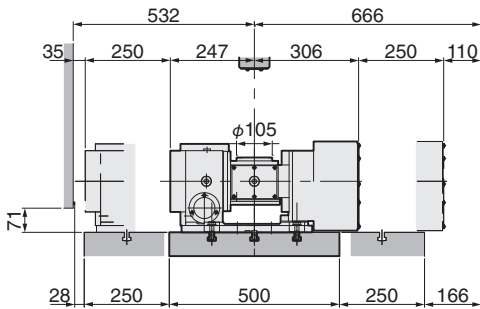

5AX-201SA-BR3



φ200mm type 5AX- TILTING ROTARY TABLE

- Diameter of Table :φ200mm
- MAX. Work Load :40kg (Vertical) 60kg (Horizontal)
- MAX. Rotation Speed :22.2 (r/min) (Rotary), 16.6 (r/min) (Tilting)
- Indexing Accuracy :±15sec. (Rotary), 60sec. (Tilting)
- Brake Torque :588Nm (Rotary), 608Nm (Tilting) (Hydraulic)
303Nm (Rotary), 303Nm (Tilting) (Pneumatic)
- Net Weight :160kg
- Servo Motor :R2AAB8100HXRGA (Rotary)
R2AAB8100HXRGA (Tilting)
- Spindle Hole :φ60mm_{H7}×φ50mm Through Hole
- Tilting Angle :0°~105°

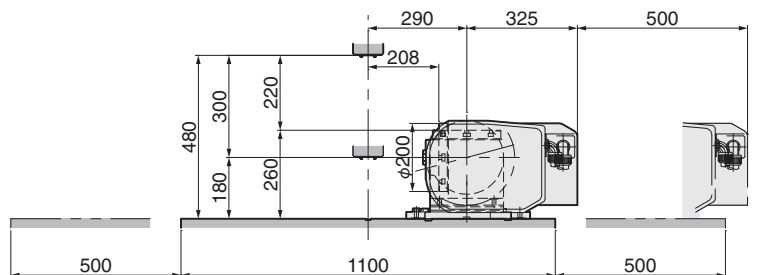
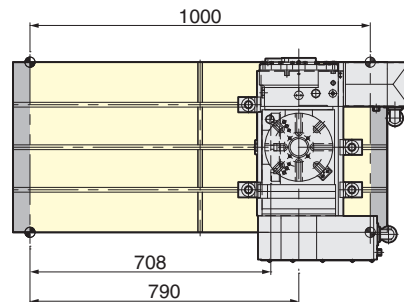
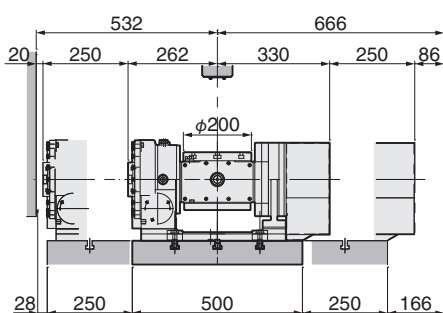

5AX-130SA-BR3

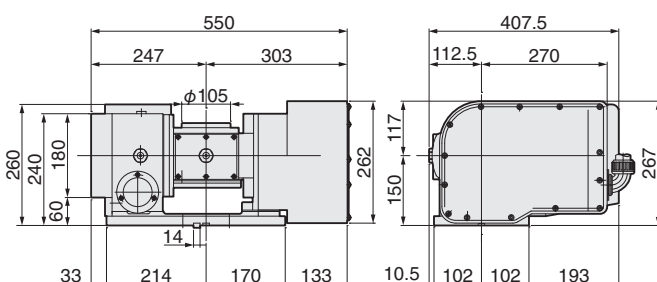

5AX-201SA-BR3

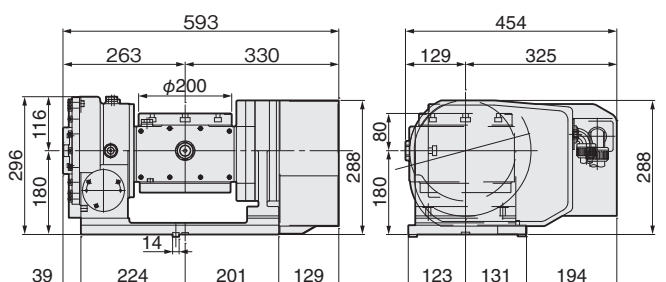

W1000Xd2

CNC ROTARY TABLE with DD MOTOR for SPEEDIO W1000Xd2 **NIKKEN**

DD250LS-50

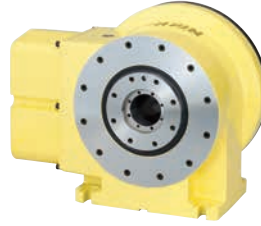

φ250mm ROTARY TABLE with DD MOTOR

- Diameter of Table : φ250mm (φ250mm sub table: Option)
- Spindle External Diameter : φ130mm
- MAX. Rotation Speed : 200r/min
- Indexing Accuracy : 15sec.
- Brake Torque : 500Nm
- Net Weight : 75kg
- Servo Motor : DB23A053021W00
- Constant Torque : 50Nm
- MAX. Torque : 200Nm
- Spindle Hole : φ53mm_{H7} Through Hole

*The color of DD250L-50 is white as standard.

Optional Accessory:
φ250mm sub table
6 ports rotary joint

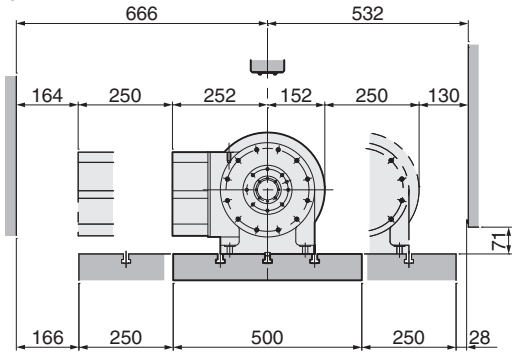
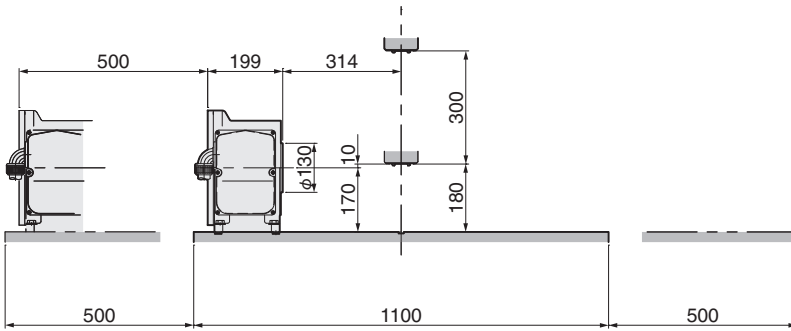
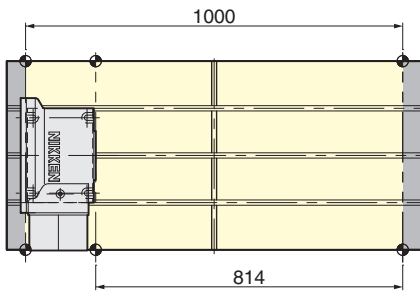

DD250LS-50

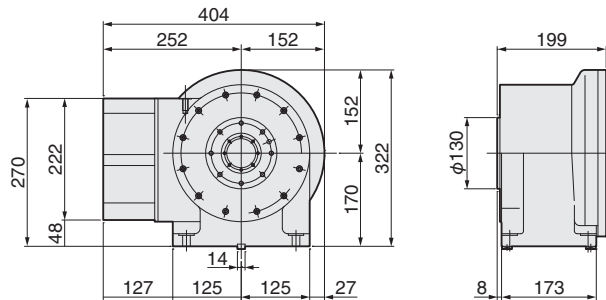

Special clamp device is needed.

⚠ Caution

■ Selection of the CNC rotary table

- The support table is basically used in case of vertical application.
- The machining operation is generally light cut on aluminium materials, however, if the fixture or the component is large size, please make sure that the fixture inertia is within the MAX. work inertia.
- If the unbalance load is too big, it will affect on not only the indexing accuracy but also the durability. Please make sure the unbalance load will be within the following figures.
CNC105 : 10Nm, CNC180, 202 : 20Nm, NCT200E, NCT200 : 20Nm, CNC260P, 302P : 30Nm
- In case of the unbalance load is large,
- The high speed Z series rotary table is not suitable, please use standard rotary table.
- Please installing the balance cylinder or counter balance.
- Please advise us the details of the component, fig fixture, indexing time etc. prior to your order, and we will make a calculation of the load and select the best suitable rotary table for your application.
- If the huge amount of coolant has to be applied, we could prepare air purge (with pneumatic pressure of 0.03MPa) on the CNC rotary table body as an option. Please contact us the details.

■ Check point for trunnion fixture

① When installing the table onto the sub-base, measure and check as follows.

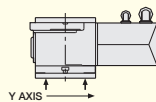

Parallelism between table & sub-base is recommended within 0.01mm

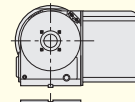

Difference between table centre and sub-base centre is recommended within 0.02mm

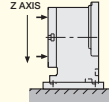

Squareness of table is recommended within 0.02mm

② Install the table & support table onto the M/C as follows.

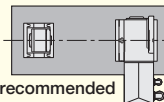

Centre lines are recommended within 0.02mm

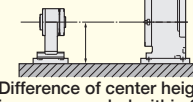

Difference of center height is recommended within 0.01mm

③ Trunnion fixture is recommended to be aligned as follows.

Squareness between center line & these faces is important

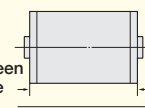

Centre of both side are recommended within 0.01mm



Squareness is important

CNC ROTARY TABLE for SPEEDIO R450Xd1



CNC105LSA-BR3

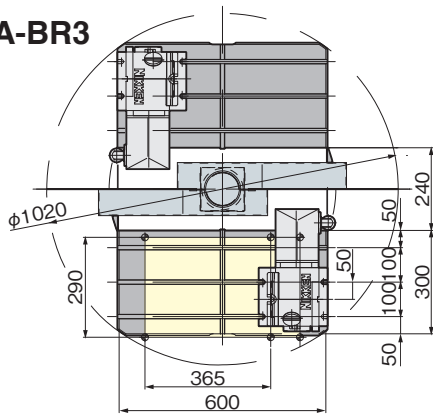

φ105mm type CNC ROTARY TABLE

- Diameter of Table : φ105mm
- MAX. Work Load : 30kg
- MAX. Rotation Speed : 33.3 (r/min), 66.6 (r/min)*1
- Indexing Accuracy : ±20sec.
- Brake Torque : 205Nm
- Net Weight : 30kg
- Servo Motor : R2AAB8100HXRGA
- Spindle Hole : φ60mm_{H7}×φ30mm Through Hole

*1:High speed Z series

4 ports rotary joint (BROTHER's option)
Please order it to BROTHER, if required.

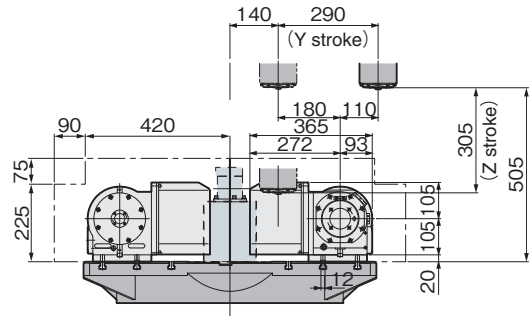
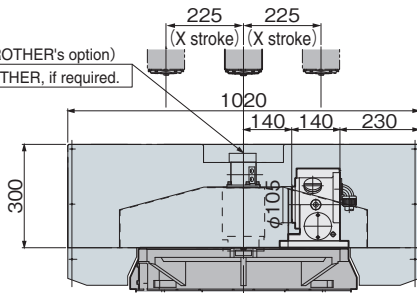

CNC ROTARY TABLE for SPEEDIO R450Xd1



CNC180LSA-BR3

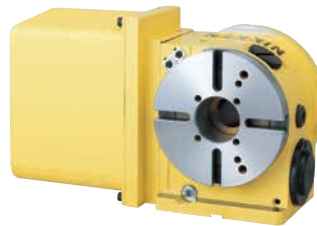
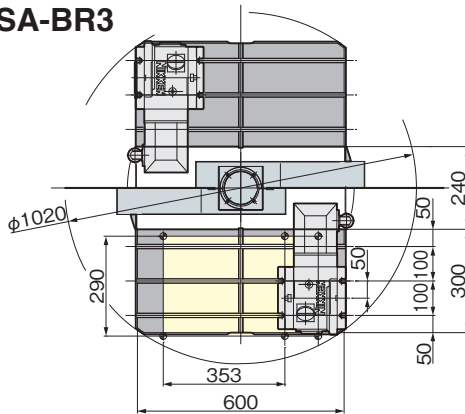

φ180mm type CNC ROTARY TABLE

- Diameter of Table : φ180mm (φ200mm)
- MAX. Work Load : 100kg (Vertical) 200kg (Horizontal)
- MAX. Rotation Speed : 33.3 (r/min), 66.6 (r/min)*1
- Indexing Accuracy : ±20sec.
- Brake Torque : 303Nm
- Net Weight : 48kg
- Servo Motor : R2AAB8100HXRGA
- Spindle Hole : φ60mm_{H7}×φ40mm Through Hole

*1:High speed Z series

4 ports rotary joint (BROTHER's option)
Please order it to BROTHER, if required.

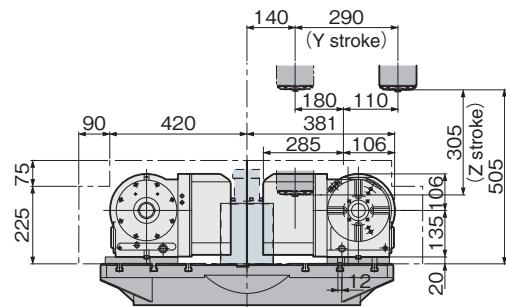
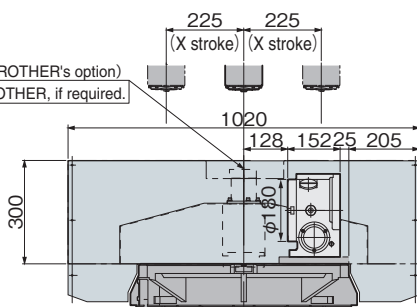

CNC105LSA-BR3

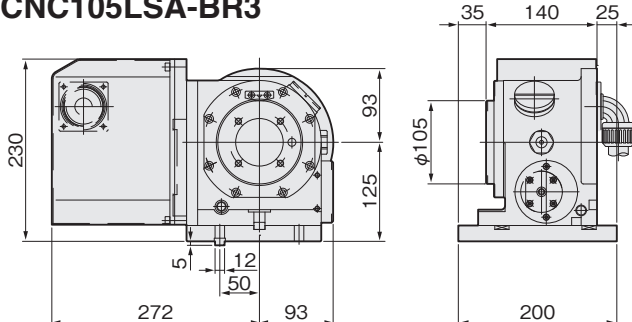

CNC180LSA-BR3

CNC202LSA-BR3 is also available

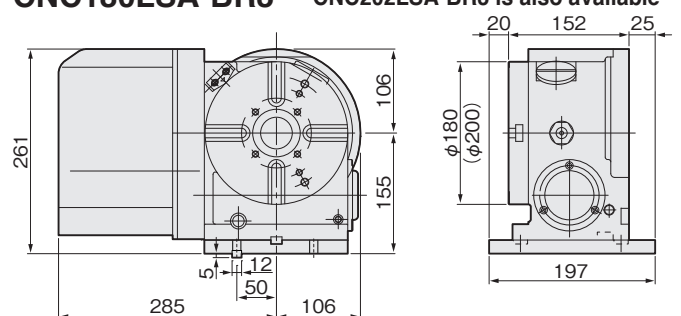

NCT ROTARY TABLE for SPEEDIO R450Xd1



NCT200ELSA-BR3

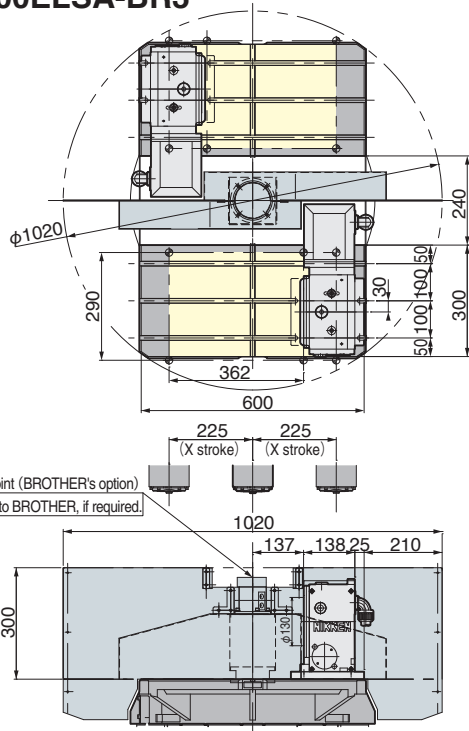

φ200mm type NCT ROTARY TABLE (Without φ200 faceplate)

- Diameter of Table :φ130mm
- MAX. Work Load :100kg (Vertical) 200kg (Horizontal)
- MAX. Rotation Speed :33.3 (r/min), **66.6 (r/min)***1
- Indexing Accuracy :±20sec.
- Brake Torque :900Nm
- Net Weight :62kg
- Servo Motor :R2AAB8100HXRGA
- Spindle Hole :φ60mm_{H7}×φ40mm Through Hole

*1:High speed Z series

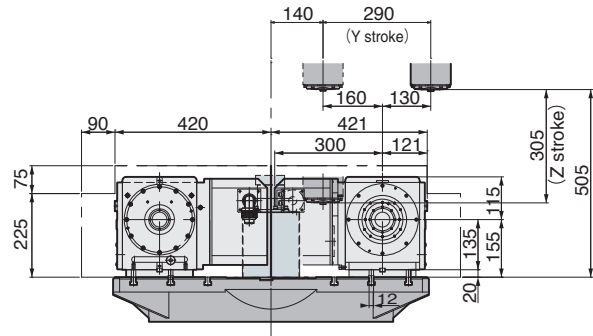

NCT200LSA-BR3

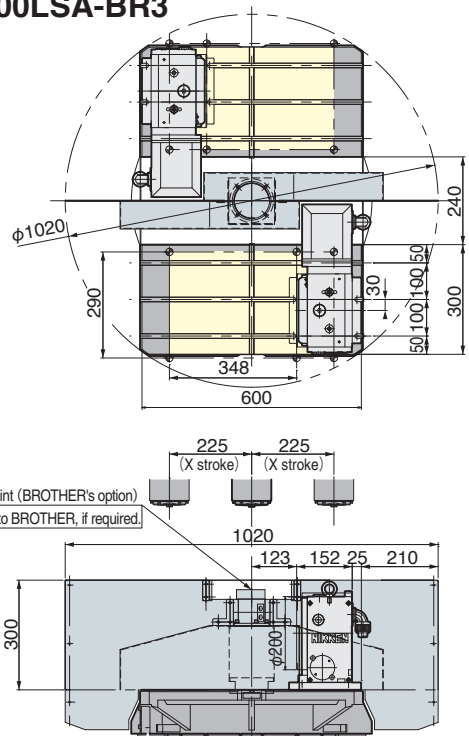

φ200mm type NCT ROTARY TABLE

- Diameter of Table :φ200mm
- MAX. Work Load :100kg (Vertical) 200kg (Horizontal)
- MAX. Rotation Speed :33.3 (r/min), **66.6 (r/min)***1
- Indexing Accuracy :±20sec.
- Brake Torque :900Nm
- Net Weight :65kg
- Servo Motor :R2AAB8100HXRGA
- Spindle Hole :φ60mm_{H7}×φ40mm Through Hole

*1:High speed Z series

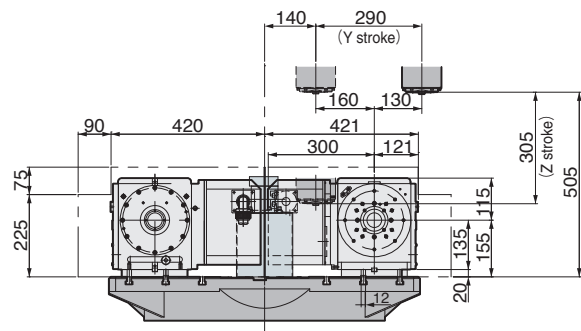

NCT200ELSA-BR3

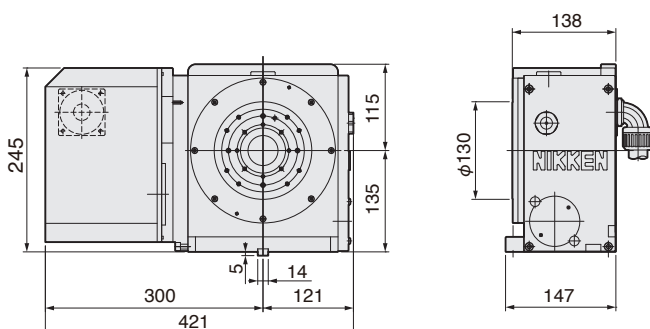

NCT200LSA-BR3

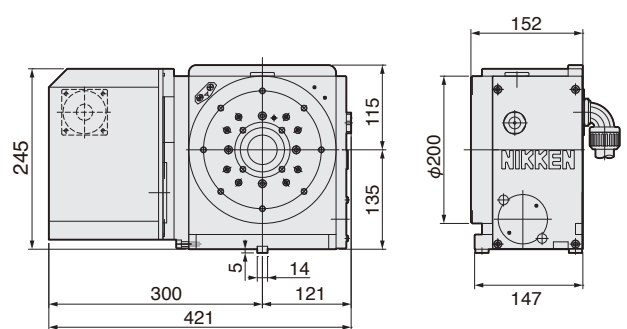

CNC ROTARY TABLE for *SPEEDIO R450Xd1*



CNC205LSA-BR3(TAT-105N-135)

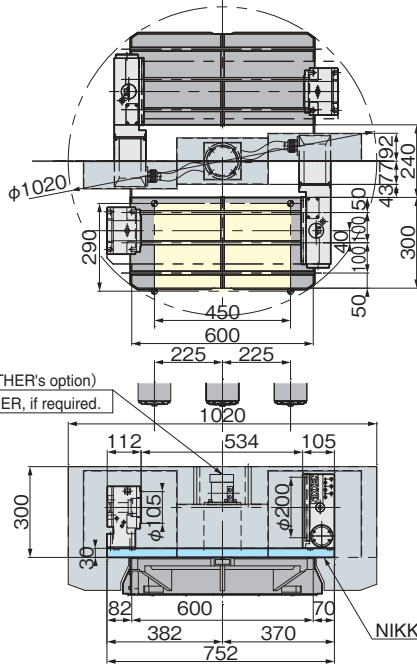

φ200mm Slim type CNC ROTARY TABLE

- Diameter of Table :φ200mm
 - MAX. Work Load :100kg (with support table)
 - MAX. Rotation Speed :33.3 (r/min), **66.6 (r/min)*1**
 - Indexing Accuracy :±20sec.
 - Brake Torque :380Nm
 - Net Weight :45kg
 - Servo Motor :R2AAB8100HXRG
 - 6 ports buit rotary joint can be fitted
- *1:High speed Z series

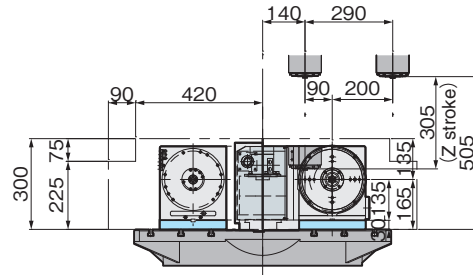

5AX- TILTING ROTARY TABLE for *SPEEDIO R450Xd1*



5AX-130BASA-BR3

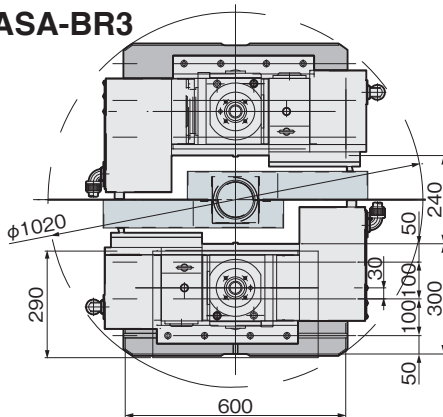

φ130mm type 5AX- TILTING ROTARY TABLE

- Diameter of Table :φ105mm (With φ130mm sub table)
 - MAX. Work Load :25kg (Vertical) 50kg (Horizontal)
 - MAX. Rotation Speed :33.3 (r/min) (Rotary), 11.1 (r/min) (Tilting)
 - Indexing Accuracy :±30sec. (Rotary), 60sec. (Tilting)
 - Brake Torque :205Nm (Rotary), 303Nm (Tilting)
 - Net Weight :160kg
 - Servo Motor :R2AAB8100HXRG (Rotary)
R2AAB8100HXRG (Tilting)
 - Spindle Hole :φ60mm_{H7}×φ30mm Through Hole
 - Tilting Angle :0°~105°
- *The photo is 5AX-130SA-BR3. *1:High speed Z series

4 ports rotary joint (BROTHER's option)
Please order it to BROTHER, if required.

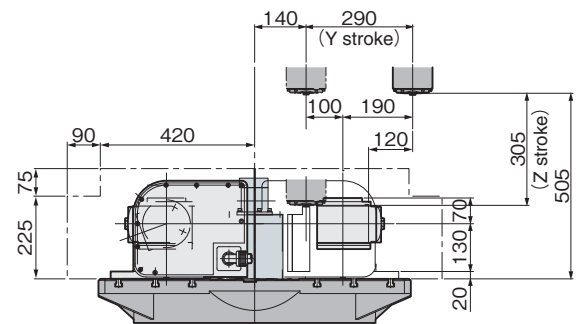
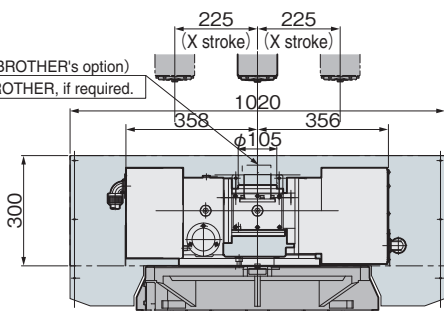

⚠ The previous agreement with BROTHER should be taken, when 2 set of 5AX-130 are installed.

CNC205LSA-BR3

TAT-105N-135

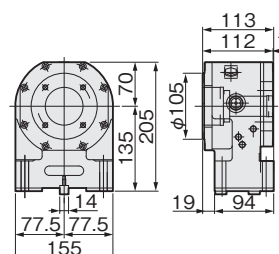
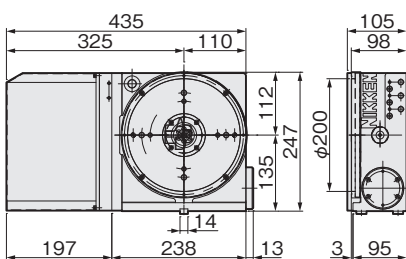

5AX-130BASA-BR3 (Tilting axis of motor rear mounting)
(Special)

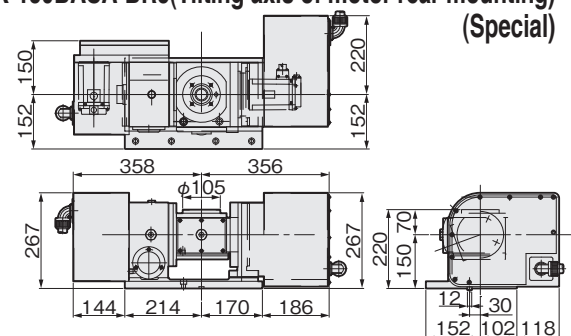

R450Xd1

CNC ROTARY TABLE for SPEEDIO R650Xd1



CNC105LSA-BR3

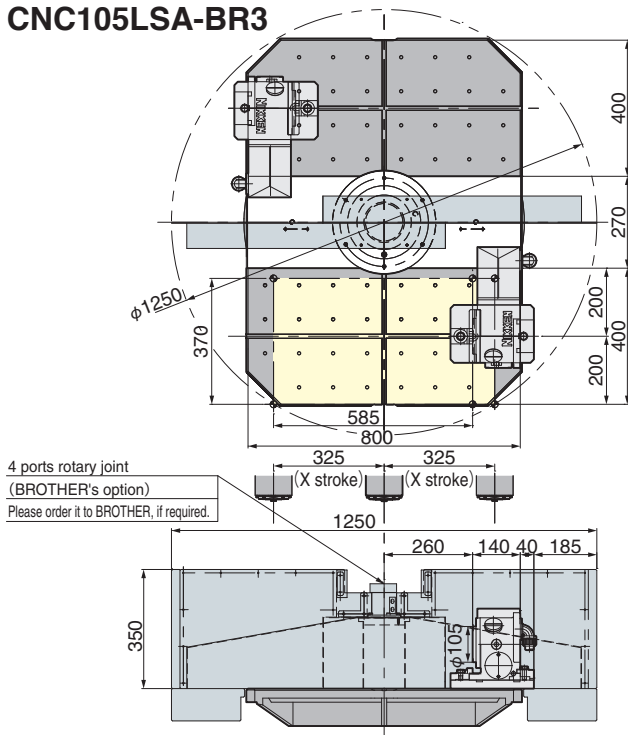

φ105mm type CNC ROTARY TABLE

- Diameter of Table :φ105mm
- MAX. Work Load :30kg
- MAX. Rotation Speed :33.3 (r/min), **66.6 (r/min)*1**
- Indexing Accuracy :±20sec.
- Brake Torque :205Nm
- Net Weight :30kg
- Servo Motor :R2AAB8100HXRG
- Spindle Hole :φ60mm_{H7}×φ30mm Through Hole

*1:High speed Z series

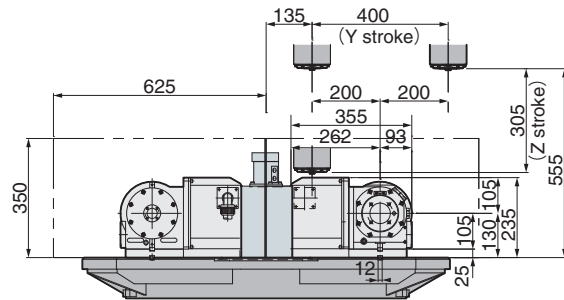

CNC180LSA-BR3

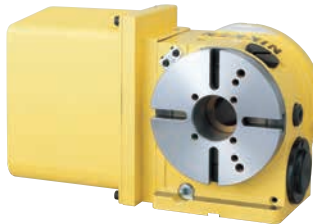
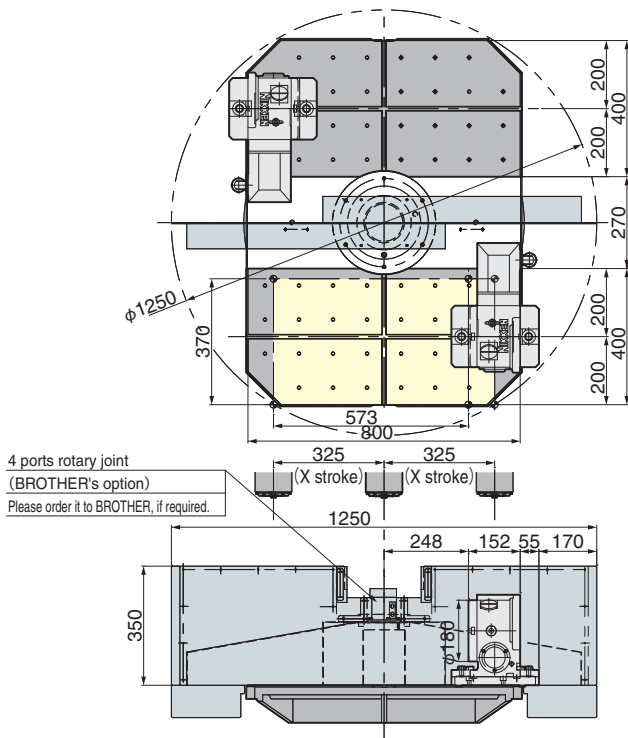

φ180mm type CNC ROTARY TABLE

- Diameter of Table :φ180mm
- MAX. Work Load :100kg (Vertical) 200kg (Horizontal)
- MAX. Rotation Speed :33.3 (r/min), **66.6 (r/min)*1**
- Indexing Accuracy :±20sec.
- Brake Torque :303Nm
- Net Weight :48kg
- Servo Motor :R2AAB8100HXRG
- Spindle Hole :φ60mm_{H7}×φ40mm Through Hole

*1:High speed Z series

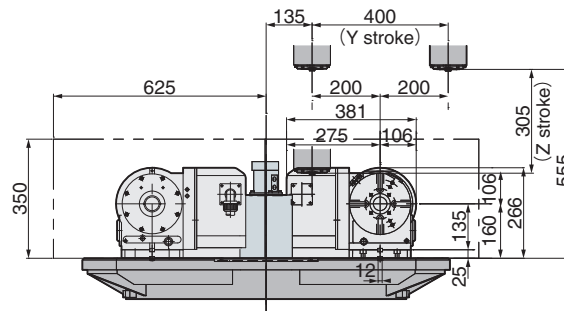

CNC105LSA-BR3

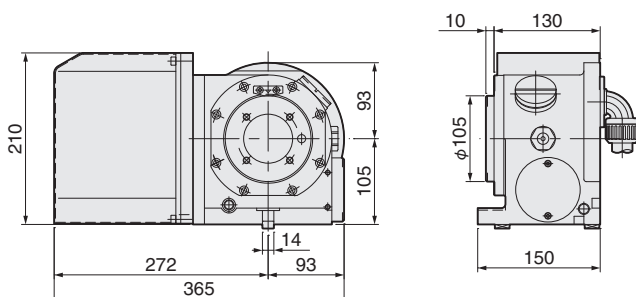

CNC180LSA-BR3 CNC202LSA-BR3 is also available

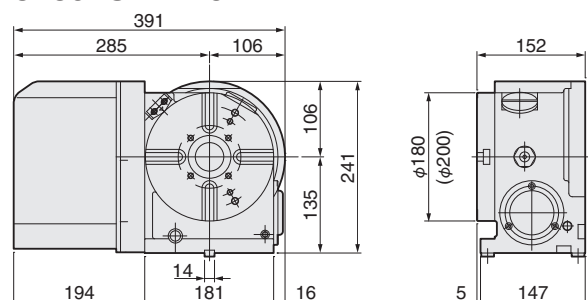

NCT ROTARY TABLE for *SPEEDIO R650Xd1*



NCT200ELSA-BR3

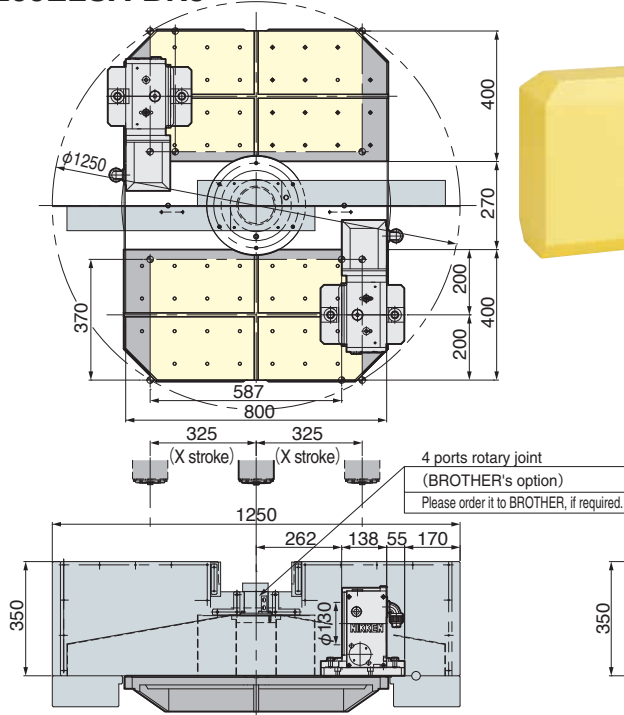

φ200mm type NCT ROTARY TABLE (Without φ200 faceplate)

- Diameter of Table :φ130mm
- MAX. Work Load :100kg (Vertical) 200kg (Horizontal)
- MAX. Rotation Speed :33.3 (r/min), **66.6 (r/min)*1**
- Indexing Accuracy :±20sec.
- Brake Torque :900Nm
- Net Weight :62kg
- Servo Motor :R2AAB8100HXRGA
- Spindle Hole :φ60mm_{H7}×φ40mm Through Hole

*1:High speed Z series

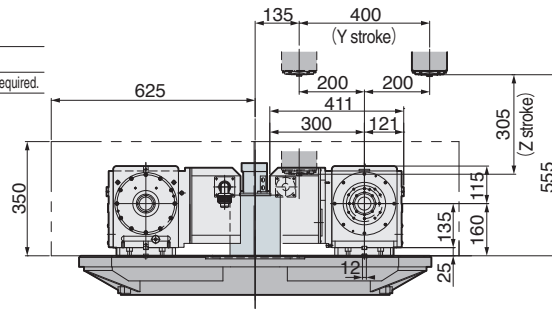

NCT200LSA-BR3

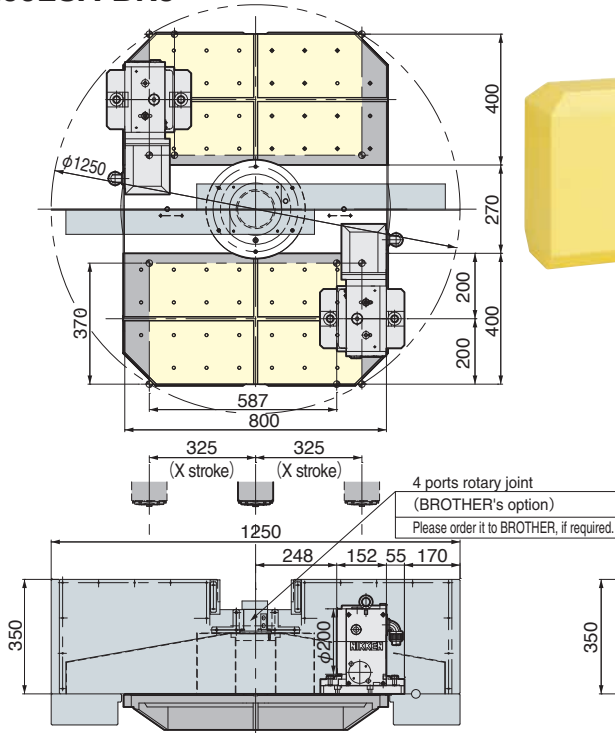

φ200mm type NCT ROTARY TABLE

- Diameter of Table :φ200mm
- MAX. Work Load :100kg (Vertical) 200kg (Horizontal)
- MAX. Rotation Speed :33.3 (r/min), **66.6 (r/min)*1**
- Indexing Accuracy :±20sec.
- Brake Torque :900Nm
- Net Weight :65kg
- Servo Motor :R2AAB8100HXRGA
- Spindle Hole :φ60mm_{H7}×φ40mm Through Hole

*1:High speed Z series

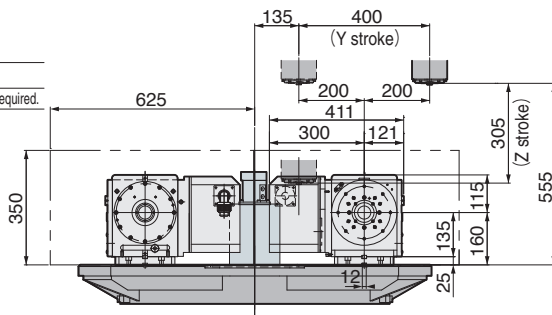

NCT200ELSA-BR3

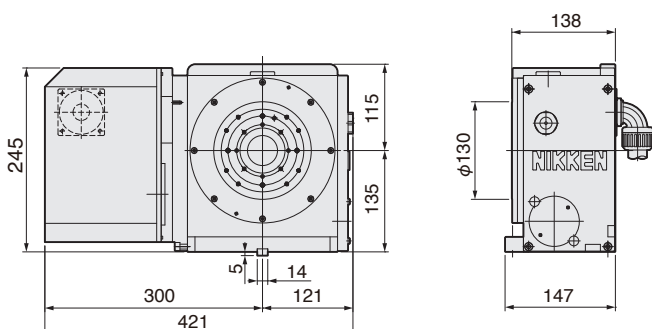

NCT200LSA-BR3

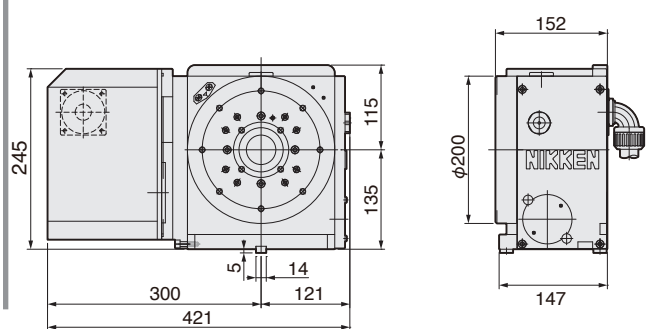

CNC ROTARY TABLE for SPEEDIO R650Xd1



CNC205LSA-BR3(TAT-105N-135)

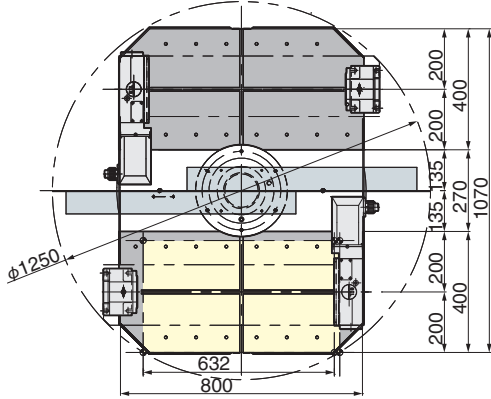

φ200mm Slim type CNC ROTARY TABLE

- Diameter of Table :φ200mm
 - MAX. Work Load :100kg (with supprt table)
 - MAX. Rotation Speed :33.3 (r/min) ,66.6 (r/min)*1
 - Indexing Accuracy :±20sec.
 - Brake Torque :380Nm
 - Net Weight :45kg
 - Servo Motor :R2AAB8100HXRGA
 - 6 ports buit rotary joint can be fitted
- *1:High speed Z series

4 ports rotary joint
(BROTHER's option)
Please order it to BROTHER, if required.

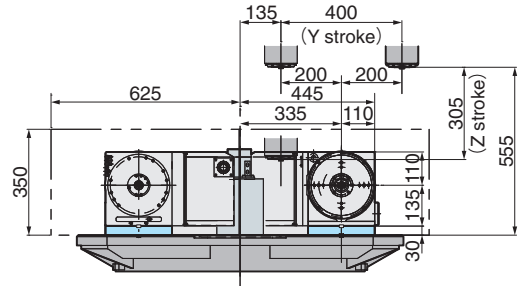
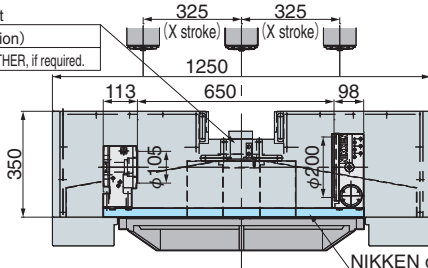

5AX- TILTING ROTARY TABLE for SPEEDIO R650Xd1



5AX-130BASA-BR3

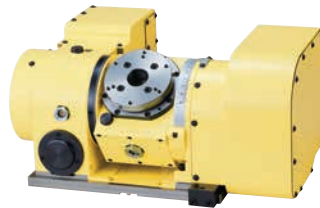
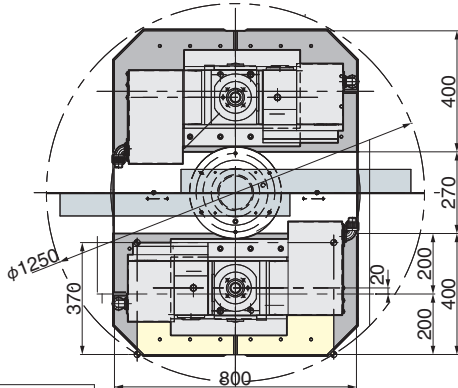

*The photo is 5AX-130SA-BR2.

φ130mm type 5AX- TILTING ROTARY TABLE

- Diameter of Table :φ105mm (With φ130mm sub table)
- MAX. Work Load :25kg (Vertical) 50kg (Horizontal)
- MAX. Rotation Speed :33.3 (r/min) (Rotary) ,11.1 (r/min) (Tilting)
- Indexing Accuracy :±30sec. (Rotary) , 60sec. (Tilting)
- Brake Torque :205Nm (Rotary) , 303Nm (Tilting)
- Net Weight :160kg
- Servo Motor :R2AAB8100HXRGA (Rotary)
R2AAB8100HXRGA (Tilting)
- Spindle Hole :φ60mm_{H7}×φ30mm Through Hole
- Tilting Angle :0°~105°

4 ports rotary joint
(BROTHER's option)
Please order it to BROTHER, if required.

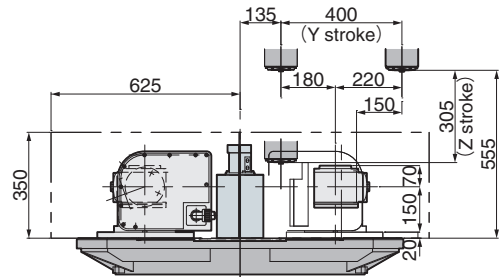
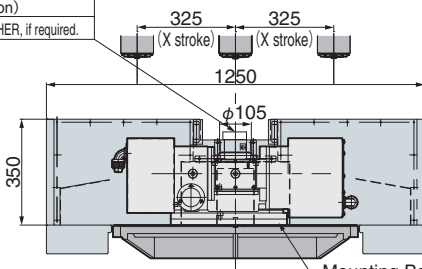

The previous agreement with BROTHER should be taken, when 2 set of 5AX-130 are installed.

CNC205LSA-BR3

TAT-105N-135

5AX-130BASA-BR3(Tilting axis of motor rear mounting)
(Special)

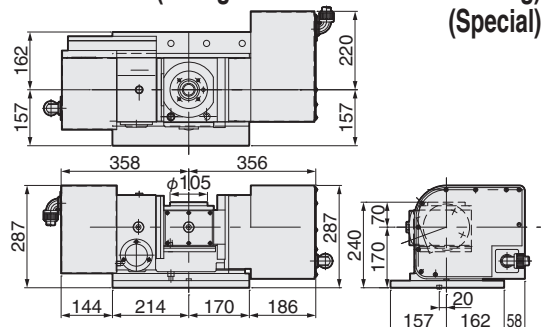
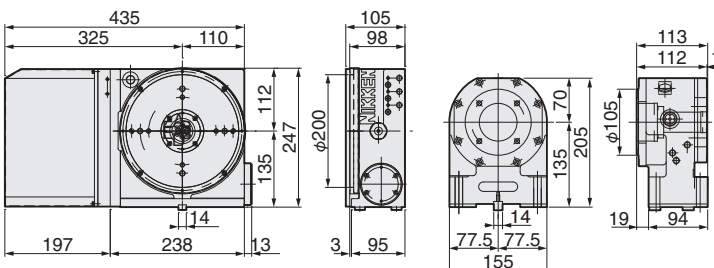

DD moter table is also possible to install to R650Xd1. Please contact us.

5AX-TILTING ROTARY TABLE with NIKKEN Controller Series **NIKKEN**

Please note below when mounting the rotary, tilting circular table to the **SPEEDIO** series manufactured by Brother Industries, Ltd.

- If you attach an additional 1 axis table to machines exported overseas, you may need export permission from the Ministry of Economy, Trade and Industry, so please consult with the distributor.
- When attaching a rotary tilt table, it is possible to use only one axis as an additional axis, but the tilt axis requires operation with M signal. (Two axis additional axis can not be retrofitted.)

By using the **AR21 controller** as the tilt axis, it is possible to operate the tilt axis using the M signal.

Features of AR21 controller **NIKKEN**

It is possible to drive the tilt axis with one M signal.

The state-of-the-art digital servo motor & absolute encoder are used.

Excellent acceleration / deceleration characteristics, optimized servo parameters for power-up motor torque realize high quality, high performance, super long life.

The **AR21 controller** can **directly command the moving angle using RS232C**, and the machine's operation program can be managed collectively by the machine side.

(There is a connection port of RS232C on the machine side, it will be available only when automatic input / output is possible with macro program.)



AR21 controller
Length×Width×Height
300mm×300mm×285mm

Product code with 1 axis Controller

5AX-100DAR21SA-BR3-A (-B) -04 -08

Diameter of Table	Product code with 1 axis controller*1	Controller size
100 : ϕ 90		-04 : 400W
130 : ϕ 130(With 130mm sub table)		-08 : 750W
201 : ϕ 200		

*1 In general it is common to have a tilt axis **with a controller**.

When **tilt axis** is to be attached with controller, **-A**

When **rotating axis** is attached with controller, it becomes **-B**.

Controller power supply breaker, M signal relay kit, controller fixing plate are included.

Wiring diagram with 1 axis controller for **SPEEDIO** **NIKKEN**

SPEEDIO Wiring diagram with 1 Axis + controller

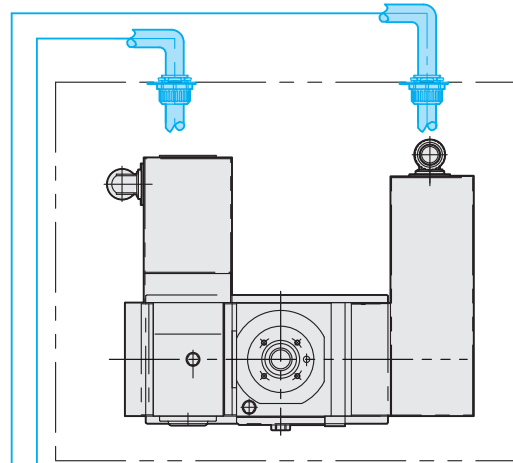
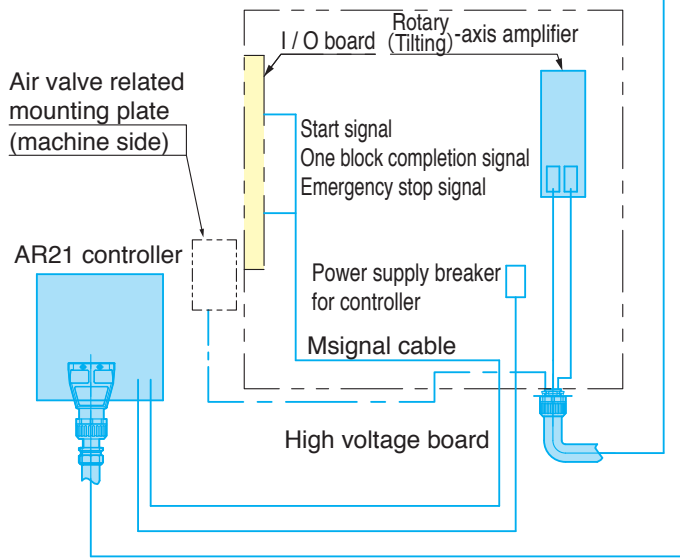

Purchase and prepare the B axis cable set necessary for additional axis control from Brother Industries through a dealer.

The parts marked in blue will be provided by Nikken Kosakusho.

5AX- TILTING ROTARY TABLE for **SPEEDIO S300Xd2** **NIKKEN**

5AX-100DAR21SA-BR3-A (-B)-04 ϕ 100mm type 5AX- TILTING ROTARY TABLE

- Diameter of Table : ϕ 90mm
- MAX. Work Load :20kg (Vertical) 40kg (Horizontal)
- MAX. Rotation Speed :44.4(r/min) (Rotary), 22.2(r/min) (Tilting)
- Indexing Accuracy : \pm 30sec. (Rotary), 60.0sec. (Tilting)
- Brake Torque :205Nm (Rotary), 600Nm (Tilting) (Hydraulic)
- Net Weight :84kg
- Tilting Angle : $0^{\circ} \sim 105^{\circ}$

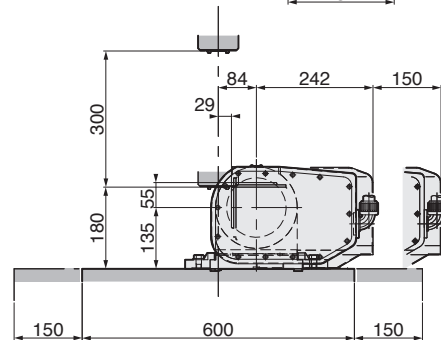
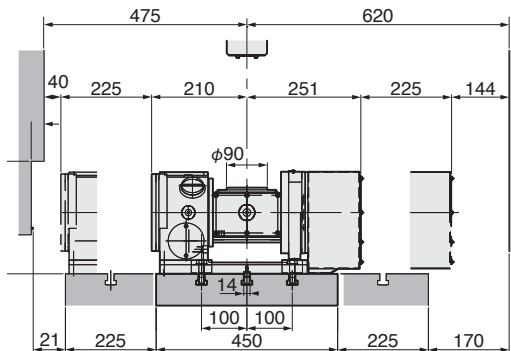
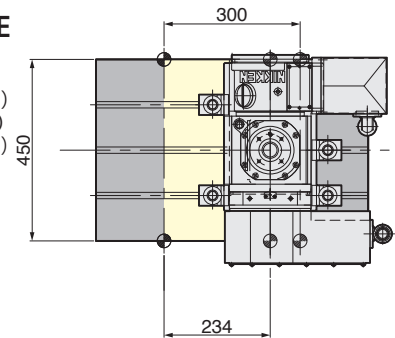

The installation drawing is an example of **SPEEDIO S300 Xd2**. Please be sure to order separately for mounting drawings on other machines

5AX-100DAR21SA-BR3-A (-B)-04

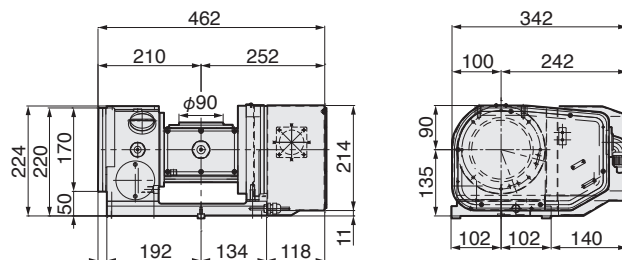

5AX- TILTING TABLE for SPEEDIO S500Xd2



5AX-130DAR21SA-BR3-A(-B)-04 ϕ 130mm type 5AX- TILTING ROTARY TABLE

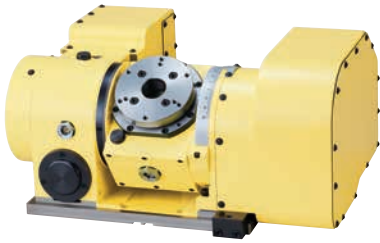

- Diameter of Table : ϕ 105mm (With ϕ 130mm sub table)
- MAX. Work Load :25kg (Vertical) 50kg (Horizontal)
- MAX. Rotation Speed :33.3 (r/min) (Rotary), 11.1 (r/min) (Tilting)
- Indexing Accuracy : \pm 30sec. (Rotary), 60.0sec. (Tilting)
- Brake Torque :205Nm (Rotary), 303Nm (Tilting)
- Net Weight :115kg
- Tilting Angle :0°~105°

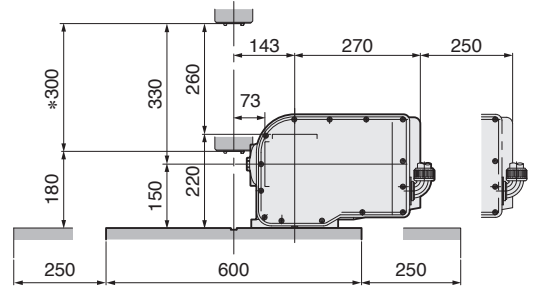
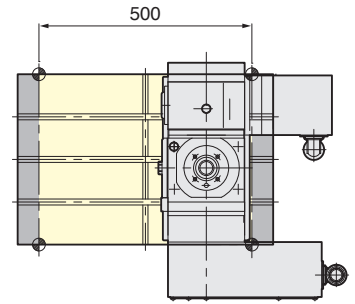
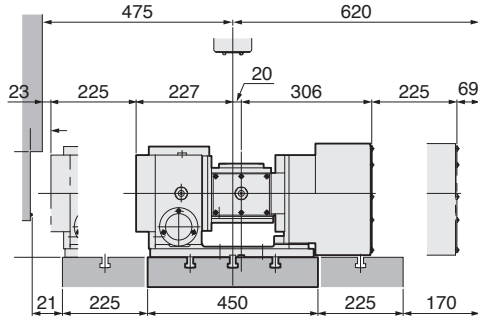

The mounting diagram is an example of **SPEEDIO S500Xd2**.
Please be sure to order separately for mounting drawings on other machines.

*Z-axis stroke of 380 mm is also available.

5AX-201DAR21SA-BR3-A(-B)-08 ϕ 200mm type 5AX- TILTING ROTARY TABLE

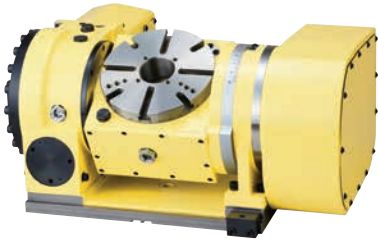

- Diameter of Table : ϕ 200mm
- MAX. Work Load :40kg (Vertical) 60kg (Horizontal)
- MAX. Rotation Speed :33.3 (r/min) (Rotary), 16.6 (r/min) (Tilting)
- Indexing Accuracy : \pm 20sec. (Rotary), 60.0sec. (Tilting)
- Brake Torque :588Nm (Rotary), 608Nm (Tilting) (Hydraulic)
303Nm (Rotary), 303Nm (Tilting) (Pneumatic)
- Net Weight :165kg
- Tilting Angle :0°~105°

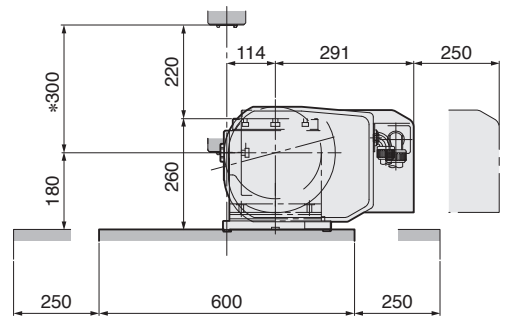
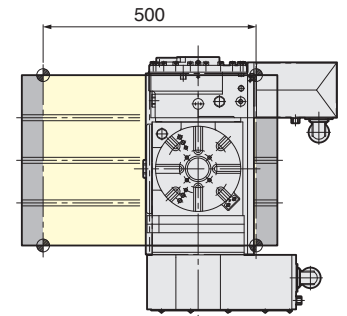
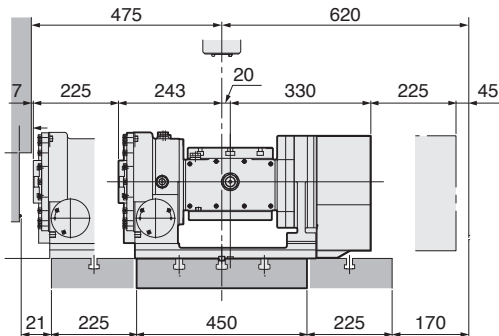

The mounting diagram is an example of **SPEEDIO S500Xd2**.
Please be sure to order separately for mounting drawings on other machines.

*Z-axis stroke of 380 mm is also available.

5AX-130DAR21SA-BR3-A(-B)-04

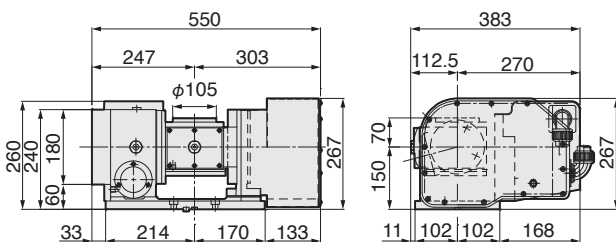

5AX-201DAR21SA-BR3-A(-B)-08

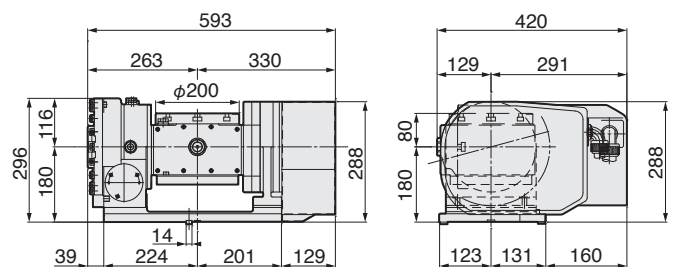

MILLING CHUCK

NIKKEN



C

Milling Chuck

Code No.	D	C1	L	ℓ ₁	Spanner
BT30-C12-55	12	33	58	58	9HC12A
-C16-55	16	44	57	65	9HC16
-C20-75	20	52	75	80	9HC22
-C25-80	25	55	82	68	9HC22
-C32-90,100	32	64	90, 100	68, 76	9HC22

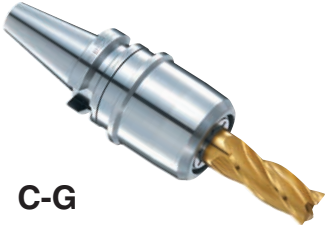

C-G

High Speed Milling Chuck

Code No.	D	C1	L	ℓ ₁	MAX. (r/min)	GH Handle
BT30-C12-55G	12	33	58	58	40,000	GH12
-C16-55G	16	44	57	65	40,000	GH16
-C20-75G	20	52	75	80	30,000	GH20
-C25-80G	25	55	82	68	25,000	GH25
-C32-90G,100G	32	64	90, 100	68, 76	10,000	GH32S

★ Tightening spanner and GH handle not included. Please order separately.
 ★ Also available for BT flange contact spindle (NBT30). Example NBT30-C12-55
 ★ Collets that can be used are KM collets, NK collets, CCK collets and CCNK collets.
 ★ NK32 and CCNK32 collets cannot be used with BT30-C32-90 and BT30-C32-90G.
 ★ NBT30-C32-90 and NBT30-C32-90G cannot use NK32 and CCNK32 collets.
 ★ For CCK and CCNK collets for coolant through, see NC General Catalogue. ★ Please refer to P.22 as for pull studs.

STRAIGHT COLLET (KM COLLET)

NIKKEN

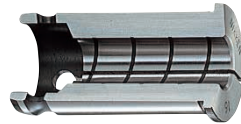
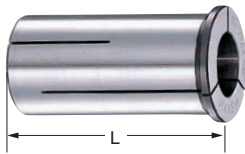

Explanation of the Code No.

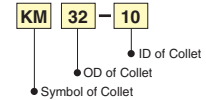

KM : Standard
 NK : Adjustable
 CCK : Centre Coolant
 CCNK : Centre Coolant, Adjustable

○ means with internal grooves for gripping strongly to eliminate the oil.

KM

Photo shows ANNIVERSARY type KM Collet.

スタイル	L	KM Collet Code No. (OD-ID)
(KM12)	40	KM12-2, 3, 4, 5, 6, 7, 8, 9, 10
(KM16)	47.5	KM16-2, 3, 4, 5, 6, 7, 8, 9, 10, 11, 12
(KM20)	53	KM20-2, 3, 4, 5, 6, 7, 8, 9, 10, 11, 12, 13, 14, 15, 16
(KM22)	57	KM22-3, 4, 5, 6, 7, 8, 9, 10, 11, 12, 13, 14, 15, 16, 17, 18, 19, 20
(KM25)	59	KM25-3, 4, 5, 6, 7, 8, 9, 10, 11, 12, 13, 14, 15, 16, 17, 18, 19, 20, 21, 22
(KM32)	64.5	KM32-3, 4, 5, 6, 7, 8, 9, 10, 11, 12, 13, 14, 15, 16, 17, 18, 19, 20, 21, 22, 23, 24, 25, 26, 30

★ [For Synchronous Tapping Program]: 5.5, 6.2, 8.5, 10.5, 12.5, 14, 15, 17, 19, 20, 23, 25, 28 Collets for Tap Shank are also available.
 ★ Please note the acceptable shank tolerance is h6~h7. ★ (): L dimension for KM42-12 or larger ID.
 ★ Collet removal (9CKR) is an optional accessory for NC milling chuck.



STRAIGHT COLLET (NK COLLET)

NIKKEN

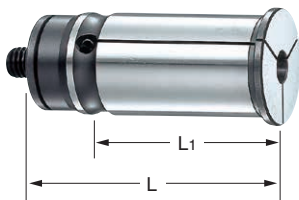

NK

Cutter length adjustment on the collet is possible from front and back.

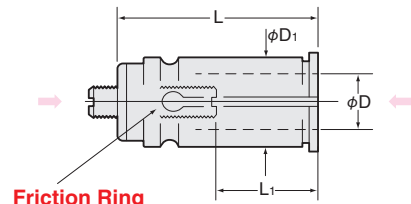

○ means with internal grooves for gripping strongly to eliminate the oil.

スタイル	L	L ₁	NK Collet Code No. (OD-ID)
(NK20)	63	20~40	NK20-3, 4, 5, 6, 7, 8, 9, 10, 11, 12, 13, 14, 15, 16
(NK22)	70	30~50	NK22-3, 4, 5, 6, 7, 8, 9, 10, 11, 12, 13, 14, 15, 16, 17, 18
(NK25)	68	30~55	NK25-3, 4, 5, 6, 7, 8, 9, 10, 11, 12, 13, 14, 15, 16, 17, 18, 19, 20, 21, 22
(NK32)	75	30~60	NK32-3, 4, 5, 6, 7, 8, 9, 10, 11, 12, 13, 14, 15, 16, 17, 18, 19, 20, 21, 22, 23, 24, 25, 26
(NK42)	85(92)	30~65	NK42-3, 4, 5, 6, 7, 8, 9, 10, 11, 12, 13, 14, 15, 16, 17, 18, 19, 20, 21, 22, 23, 24, 25, 26, 27, 28, 29, 30, 31, 32

★ [For Synchronous Tapping Program]: 5.5, 6.2, 8.5, 10.5, 12.5, 14, 15, 17, 19, 20, 23, 25, 28 Collets for Tap Shank are also available.
 ★ Other metric sizes and imperial sizes, 1/8, 1/4, 5/16, 3/8, 7/16, 1/2, 5/8, 3/4, 13/16, 7/8, 1, 1-1/8, 1-1/4, 1-1/2 are also available.
 ★ Please note the acceptable shank tolerance is h6~h7. ★ The collets with bold character are standard.
 ★ Collet removal (9CKR) is an optional accessory for NC milling chuck.
 ★ NK32 collets cannot be used with BT30-C32-90 and BT30-C32-90G.



TOOL

SLIM CHUCK HIGH SPEED ROTATION•HIGH ACCURACY



Slim Chuck



SK

Code No.	D	C	L	ℓ ₁	Collet	Spanner
BT30-SK 6-60,90,120,150	0.7~6.0	19.5	60,90,120,150	35,35,35,35	SK 6	SKL-6W
-SK10-45,60, 75, 90,120,150	1.75~10.0	27.5	45,60,75,90,120,150	50,50,50,50,50,50	SK10	SKL-10W
-SK13-60,75, 90,120	2.75~13.0	33.0	60,75,90,120	50,65,65,65	SK13	9HC12A
-SK16-60,75, 90,120	2.75~16.0	40.0	60,75,90,120	60,65,65,70	SK16	9HC16
-SK20-60,75, 90	3.5~20.0	48.5	60,75,90	70,75,75	SK20	9HC22
-SK25-90	7.5~25.4	55.0	90	75	SK25	9HC22

High Speed Slim Chuck



SK-P

Code No.	D	C	L	ℓ ₁	Collet	MAX. (r/min)	GH Handle
BT30-SK 6-60P,90P,120P	0.7~6.0	19.5	60,90,120,150	35,35,35,35	SK 6	40,000	GH6
-SK10-45P,60P,75P, 90P,120P	1.75~10.0	27.5	45,60,75,90,120,150	50,50,50,50,50,50	SK10	40,000	GH10
-SK13-60P,75P,90P,120P	2.75~13.0	33.0	60,75,90,120	50,65,65,65	SK13	40,000	GH12
-SK16-60P,75P,90P,120P	2.75~16.0	40.0	60,75,90,120	60,65,65,70	SK16	30,000	GH16
-SK20-60P,75P,90P	3.5~20.0	48.5	60,75,90	70,75,75	SK20	30,000	GH20
-SK25-90P	7.5~25.4	55.0	90	75	SK25	30,000	GH25

★TIN bearing nuts are supplied. Tightening spanner is not included. Please order separately.

★Also available for BT flange contact spindle (NBT30). Example NBT30-SK6C-60

★Collets that can be used are SK collets, SK-P collets, SK-A collets and SK-AC collets.

★For adjusting screws for cutting tool protrusion adjustment, see the NC General Catalogue. ★Please refer to P.22 as for pull studs.

SLIM CHUCK COLLET (SKCOLLET)



SK

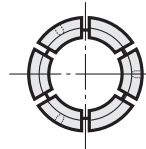
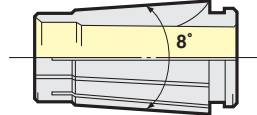

Explanation of the Code No.

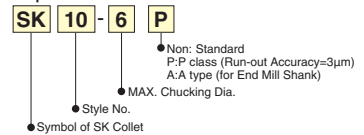

“A” type SK collet (for End Mill Shank) are marked **P**. The acceptable shank tolerance is h₈. Code No. is e.g. SK10-10A
 “P” class SK collet (for drill) are available for all series. e.g. SK10-10P

Code No.	Chucking D
SK 6- 0.8	0.7 ~ 0.8
- 1	0.9 ~ 1.0
- 1.25	1.15~ 1.25
- 1.5	1.3 ~ 1.5
- 1.75	1.55~ 1.75
- 2	1.8 ~ 2.0
- 2.25	2.05~ 2.25
- 2.5	2.3 ~ 2.5
- 2.75	2.55~ 2.75
- 3	2.8 ~ 3.0
- 3.5	3.0 ~ 3.5
- 4	3.5 ~ 4.0
- 4.5	4.0 ~ 4.5
- 5	4.5 ~ 5.0
- 5.5	5.0 ~ 5.5
- 6	5.5 ~ 6.0
SK10- 1	0.9 ~ 1.0
- 1.25	1.15~ 1.25
- 1.5	1.3 ~ 1.5
- 1.75	1.55~ 1.75
- 2	1.75~ 2.0
- 2.25	2.0 ~ 2.25
- 2.5	2.25~ 2.5
- 2.75	2.5 ~ 2.75
- 3	2.75~ 3.0
- 3.5	3.0 ~ 3.5
- 4	3.5 ~ 4.0
- 4.5	4.0 ~ 4.5
- 5	4.5 ~ 5.0
- 5.5	5.0 ~ 5.5
- 6	5.5 ~ 6.0
- 6.5	6.0 ~ 6.5
- 7	6.5 ~ 7.0
- 7.5	7.0 ~ 7.5
- 8	7.5 ~ 8.0
- 8.5	8.0 ~ 8.5
- 9	8.5 ~ 9.0
- 9.5	9.0 ~ 9.5
- 10	9.5 ~ 10.0

Code No.	Chucking D
SK13- 3	2.75~ 3.0
- 3.5	3.0 ~ 3.5
- 4	3.5 ~ 4.0
- 4.5	4.0 ~ 4.5
- 5	4.5 ~ 5.0
- 5.5	5.0 ~ 5.5
- 6	5.5 ~ 6.0
- 6.5	6.0 ~ 6.5
- 7	6.5 ~ 7.0
- 7.5	7.0 ~ 7.5
- 8	7.5 ~ 8.0
- 8.5	8.0 ~ 8.5
- 9	8.5 ~ 9.0
- 9.5	9.0 ~ 9.5
- 10	9.5 ~ 10.0
- 10.5	10.0~10.5
- 11	10.5~11.0
- 11.5	11.0~11.5
- 12	11.5~12.0
- 12.5	12.0~12.5
- 13	12.5~13.0

Code No.	Chucking D
SK16- 3	2.75~ 3.0
- 3.5	3.0 ~ 3.5
- 4	3.5 ~ 4.0
- 4.5	4.0 ~ 4.5
- 5	4.5 ~ 5.0
- 5.5	5.0 ~ 5.5
- 6	5.5 ~ 6.0
- 6.5	6.0 ~ 6.5
- 7	6.5 ~ 7.0
- 7.5	7.0 ~ 7.5
- 8	7.5 ~ 8.0
- 8.5	8.0 ~ 8.5
- 9	8.5 ~ 9.0
- 9.5	9.0 ~ 9.5
- 10	9.5 ~ 10.0
- 10.5	10.0~10.5
- 11	10.5~11.0
- 11.5	11.0~11.5
- 12	11.5~12.0
- 12.5	12.0~12.5
- 13	12.5~13.0
- 13.5	13.0~13.5
- 14	13.5~14.0
- 14.5	14.0~14.5
- 15	14.5~15.0
- 15.5	15.0~15.5
- 16	15.5~16.0

Code No.	Chucking D
SK20- 4	3.5 ~ 4.0
- 4.5	4.0 ~ 4.5
- 5	4.5 ~ 5.0
- 5.5	5.0 ~ 5.5
- 6	5.5 ~ 6.0
- 6.5	6.0 ~ 6.5
- 7	6.5 ~ 7.0
- 7.5	7.0 ~ 7.5
- 8	7.5 ~ 8.0
- 8.5	8.0 ~ 8.5
- 9	8.5 ~ 9.0
- 9.5	9.0 ~ 9.5
- 10	9.5 ~ 10.0
- 10.5	10.0~ 10.5
- 11	10.5~ 11.0
- 11.5	11.0~ 11.5
- 12	11.5~ 12.0
- 12.5	12.0~ 12.5
- 13	12.5~ 13.0
- 13.5	13.0~ 13.5
- 14	13.5~ 14.0
- 14.5	14.0~ 14.5
- 15	14.5~ 15.0
- 15.5	15.0~ 15.5
- 16	15.5~ 16.0
- 16.5	16.0~ 16.5
- 17	16.5~ 17.0
- 17.5	17.0~ 17.5
- 18	17.5~ 18.0
- 18.5	18.0~ 18.5
- 19	18.5~ 19.0
- 19.5	19.0~ 19.5
- 20	19.5~ 20.0

Code No.	Chucking D
SK25- 8	7.5~8.0
- 10	9.5~10.0
- 12	11.5~12.0
- 16	15.5~16.0
- 16.5	16.0~16.5
- 17	16.5~17.0
- 17.5	17.0~17.5
- 18	17.5~18.0
- 18.5	18.0~18.5
- 19	18.5~19.0
- 19.5	19.0~19.5
- 20	19.5~20.0
- 20.5	20.0~20.5
- 21	20.5~21.0
- 21.5	21.0~21.5
- 22	21.5~22.0
- 22.5	22.0~22.5
- 23	22.5~23.0
- 23.5	23.0~23.5
- 24	23.5~24.0
- 24.5	24.0~24.5
- 25	24.5~25.0
- 25.4	25.0~25.4



Collet removal (SKR-6) is supplied as standard only for SK6. SKR-10, SKR-16 and SKR-25 are available as an option. Collet removal is not necessary for the new types of collet (SK10 to SK25 collet including SK13 and SK20).

- ★Collets with special inner diameters can also be manufactured.
- ★Please refer to P.17 as for SK coolant collet (AC collet).
- ★Please refer to P.17 as for the jet coolant system and the system for oil hole drill.
- ★When gripping a cutting tool of less than nominal size with the SK collet, please be careful that the tool protrusion will be shortened.

SLIM CHUCK COLLET (P CLASS / A TYPE COLLET) **NIKKEN**

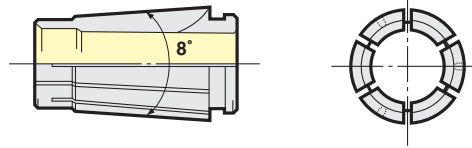

Explanation of the Code No.

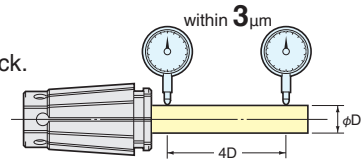
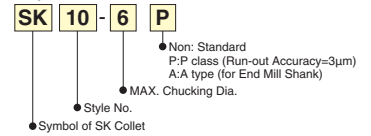

“P” class SK collet for drill

It guarantees the Run-out accuracy within 3 micron at the nose (4D) from the chuck. Additionally Collet Set is also available.

“A” type SK collet for endmill

The acceptable shank tolerance is h8.

★When using A TYPE SLIM COLLET, the L-dimension of the chuck will be shorter by about 3mm. Please be careful when you check the interference.

SK Collet A Type
SK 6-3A, 4A, 5A, 6A
SK10-3A, 4A, 5A, 6A, 8A, 10A
SK13-3A, 4A, 5A, 6A, 8A, 10A, 12A, 13A
SK16-3A, 4A, 5A, 6A, 8A, 10A, 12A, 16A
SK20-4A, 5A, 6A, 8A, 10A, 12A, 16A, 20A
SK25-8A, 10A, 12A, 16A, 20A, 25A

SK Collet A Type (Inch)
SK 6 -1/8A, 3/16A
SK10 -1/8A, 3/16A, 1/4A, 5/16A, 3/8A
SK13 -1/8A, 3/16A, 1/4A, 5/16A, 3/8A, 7/16A, 1/2A
SK16 -1/8A, 3/16A, 1/4A, 5/16A, 3/8A, 7/16A, 1/2A, 9/16A, 5/8A
SK20 -1/8A, 3/16A, 1/4A, 5/16A, 3/8A, 7/16A, 1/2A, 9/16A, 5/8A, 3/4A
SK25 -3/16A, 1/4A, 5/16A, 3/8A, 7/16A, 1/2A, 5/8A, 3/4A, 25.4A

CENTER-THRU COOLANT COLLET (SK-AC) for NIKKEN SLIM CHUCK **NIKKEN**

Collets with sealing function for cutting tools with oil hole.

★When using AC COLLET, the L-dimension of the chuck will be shorter by about 3mm. Please be careful when you check the interference.

SK Collet A Type
SK 6-3AC, 4AC, 5AC, 6AC
SK10-3AC, 4AC, 5AC, 6AC, 7AC, 8AC, 9AC, 10AC
SK13-4AC, 5AC, 6AC, 7AC, 8AC, 9AC, 10AC, 11AC, 12AC
SK16-6AC, 7AC, 8AC, 9AC, 10AC, 11AC, 12AC, 13AC, 14AC, 15AC, 16AC
SK20-12AC, 13AC, 14AC, 15AC, 16AC, 17AC, 18AC, 19AC, 20AC
SK25-16AC, 20AC, 25AC

Code number reference

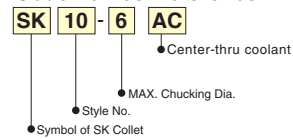

SLIM CHUCK COOLANT SOLUTION **NIKKEN**

WITH OIL HOLE DRILL

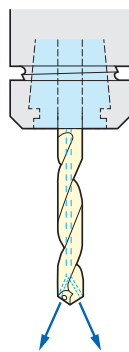

1 Standard Nut + SK-AC Coolant Collet

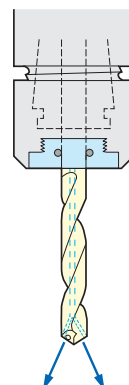

2 J-TYPE Nut with Standard Collet and J CAP(C)

JET COOLANT SYSTEM

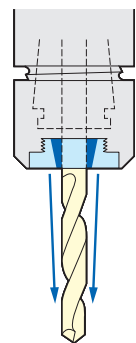

3 J-TYPE Nut with Standard Collet and J CAP

★Please refer to NC catalog for coolant solutions.

2LOCK Major Dream Holder

MDSK



Code No.	D	C	L	ℓ	Collet	GH Handle
NBT30-MDSK- 6-50,60,75,90	3.0 ~ 6.0	19.5	50,60,75,90	35,35,35,35	SK 6 A, AC	GH 6
-10-50,60,75,90	3.0 ~10.0	27.5	50,60,75,90	50,50,50,50	SK10 A, AC	GH10
-13-60,75,90	3.0 ~13.0	33.0	60,75,90	43,60,60	SK13 A, AC	GH12
-16-75,90	3.0 ~16.0	40.0	75,90	60,70	SK16 A, AC	GH16

High Speed 2LOCK Major Dream Holder

MDSK-P



Code No.	D	C	L	ℓ	Collet	MAX. (r/min)	GH Handle
NBT30-MDSK- 6-50P,60P,75P,90P	3.0 ~ 6.0	19.5	50,60,75,90	35,35,35,35	SK 6 A, AC	30,000	GH 6
-10-50P,60P,75P,90P	3.0 ~10.0	27.5	50,60,75,90	50,50,50,50	SK10 A, AC	30,000	GH10
-13-60P,75P,90P	3.0 ~13.0	33.0	60,75,90	43,60,60	SK13 A, AC	30,000	GH12
-16-75P,90P	3.0 ~16.0	40.0	75,90	60,70	SK16 A, AC	25,000	GH16

★Please use A type SK collet for the end milling operation.
★Please refer to NC catalog for coolant solutions.

★GH handle is available as an option.
★Please refer to P.22 as for pull studs.

MINI-MINI CHUCK ADVANCED ALPHA

MMC

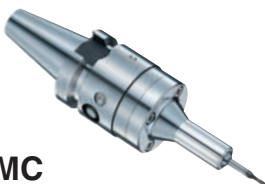

Code No.	D	D1	L	MAX. (r/min)	Wrench
BT30-MMC 4 -105-AA	1.0~ 4.0	15.0	105	30,000	EA573KL-6
-MMC 8C-105-AA	2.0~ 8.0	20.0	105	30,000	EA573KL-6
-MMC12C-105-AA	4.0~12.0	30.0	105	30,000	MMCL12-M6W

★Spanners are supplied with the mini-mini chuck. Collets are not included and must be ordered separately.
★Also available for BT flange contact spindle (NBT30). Example NBT30-MMC4C-105-AA
★Please refer to NC catalog for coolant solutions. ★Please refer to P.22 as for pull studs.

DIRECT SCREW TYPE MINI-MINI CHUCK

MMC-AT



Code No.	D	D1	L	MAX. (r/min)	Wrench
BT30-MMC8C-65-AT	2.0~8.0	20.0	65	30,000	EA573KL-15

★Spanners are supplied with the mini-mini chuck. Collets are not included and must be ordered separately.
★Code No. of spanner for pull-stud tightening spanner sold separately is MMCLA-BT30. Please order separately.
★Also available for BT flange contact spindle (NBT30). Example NBT30-MMC8C-65-AT
★Please refer to NC catalog for coolant solutions. ★Please refer to P.22 as for pull studs.

MINI-MINI COLLET (MPK/PMK/VMK COLLET)

STANDARD COLEET : MPK Collet / PMK Collet

FOR CENTRE THROUGH TOOL COOLANT : VMK Collet / VMK-J Collet

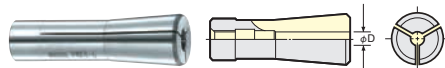

Explanation of the Code No.
PMK 8 - 2
● ID of Collet
● Style No.
● Symbol of PMK collet

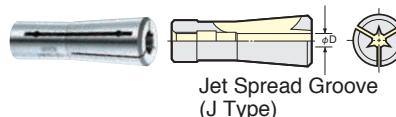

Explanation of the Code No.
VMK 12 - 6 J
● Non: Without Jet Spread Groove
● J : With Jet Spread Groove
● ID of Collet
● Style No.
● Symbol of VMK collet

Code No.	Min. Gripping Length
MPK 4 - 1	6
- 1.5	8
- 2	10
- 2.5	12
- 3	16
- 3.5	16
- 4	16
- 1/16	8
- 3/32	10
- 1/8	16

Code No.	Min. Gripping Length
PMK 8 - 2	10
- 2.2	10
- 2.4	12
- 2.6	12
- 2.8	12
- 3	16
- 3.2	16
- 3.4	16
- 3.6	16
- 3.8	16
- 4	20
- 4.2	20
- 4.4	20
- 4.6	22
- 4.8	22
- 5	22
- 5.2	22
- 5.4	22
- 5.6	22
- 5.8	22
- 6	22
- 6.2	22
- 6.4	22
- 6.6	22

Code No.	Min. Gripping Length
PMK 8 - 6.8	22
- 7	22
- 7.2	22
- 7.4	22
- 7.6	22
- 7.8	22
- 8	22
- 1/8	16
- 3/16	22
PMK 12 - 4	19
- 5	22
- 6	30
- 8	31
- 10	31
- 12	31

Code No.	Min. Gripping Length
VMK 8 - 2	10
- 3	16
- 4	20
- 5	22
- 6	22
- 7	22
- 8	22
- 2 J	10
- 3 J	16
- 4 J	20
- 5 J	22
- 6 J	22
- 7 J	22
- 8 J	22
- 1/8	15
- 3/16	22
- 1/4	22
- 5/16	22
- 3/8	22
- 1/8 J	16
- 3/16 J	22
- 1/4 J	22
- 5/16 J	22
- 3/8 J	22

Code No.	Min. Gripping Length
VMK12 - 4	19
- 5	22
- 6	30
- 8	31
- 10	31
- 12	31
- 4 J	19
- 5 J	22
- 6 J	30
- 8 J	31
- 10 J	31
- 12 J	31
- 3/16	22
- 1/4	30
- 5/16	31
- 3/8	31
- 7/16	31
- 1/2	31
- 3/16 J	22
- 1/4 J	30
- 5/16 J	31
- 3/8 J	31
- 7/16 J	31
- 1/2 J	31

Jet spread Hole Type
VMK8-2J,
VMK8-3J

★Please note the acceptable shank tolerance of MPK Collet is h6.

★Even the gripping range of PMK Collet is 0.2mm / dia. (e.g. PMK8-2 : 1.8~2.0) but the shank tolerance of h6 highly recommended for precision machining.

★For Centre through tool Coolant type MINI-MINI Chuck :

★VMK-J Collet is for the cutting tool without Coolant hole.

★VMK8-2J is Jet Spread Hole type.

★Standard VMK Collet is for the cutting tool with coolant hole.

★Please note the acceptable shank tolerance h6.

★VMK-2J and VMK-3J will be replaced with

VMK-2JB and VMK-3JB as soon as the stock is runs out.

MODULAR TYPE RAC BORING HEAD

NIKKEN

RAC-E Balance-Cut Boring Head

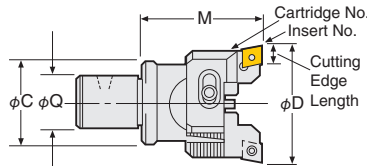

For Steel, Stainless Steel
and Cast Iron
CC Insert (Positive type)

Head Code No.	Boring Range D	Boring Depth M	Coupling Dia Q	C	Cartridge No.	Insert No.	Cutting Edge Length	Weight (Kg)
12-RAC 25 - 55E	25~32	55	12	24	RCC-025E	CC07	8.0	0.4
16-RAC 32 - 55E	32~45		16	31	RCC-32E	CC08	9.7	0.5
20-RAC 43 - 70E	43~55	70	20	40	RCC-43E	CC12	12.9	0.7
26-RAC 53 - 70E	53~70		26	50	RCC-53E			0.8
26-RAC 70 - 70E*	70~100				RCC-70E			1.0

★Code No. of RAC25 and RAC32 with CC inserts are changed to RAC25E and RAC32E. ★Insert tips are supplied as an option. ☞ P.21 Please refer NC TOTAL TOOLING SYSTEM for cutting condition.
★For centre through coolant type, please add "C" at the end of Code No. e.g. 26-RAC53-70E-C *Mark : 26-RAC70-70E is not available with oil hole specification.

RAC-A Balance-Cut Boring Head

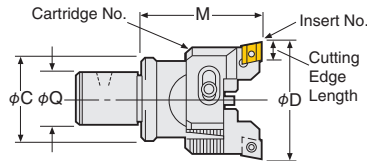
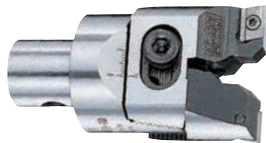

For Aluminum

Head Code No.	Boring Range D	Boring Depth M	Coupling Dia Q	C	Cartridge No.	Insert No.	Cutting Edge Length	Weight (Kg)
12-RAC 25 - 55A	25~32	55	12	24	RCC-25A	AEG12	9.5	0.4
16-RAC 32 - 55A	32~45		16	31	RCC-32A			0.5
20-RAC 43 - 70A	43~55	70	20	40	RCC-43A	AEG16	15.875	0.7
26-RAC 53 - 70A	53~70		26	50	RCC-53A			0.8
26-RAC 70 - 70A*	70~100				RCC-70A			1.0

★For centre through coolant type, please add "C" at the end of Code No. e.g. 26-RAC53-70A-C *Mark : 26-RAC70-70A is not available with oil hole specification.
★Insert tips are supplied as an option. ☞ P.21 ★For heavy cutting (RAC), through-hole and multi-plate (RAC-K) other than the above, please refer NC TOTAL TOOLING SYSTEM.
★Please refer NC TOTAL TOOLING SYSTEM for cutting condition.

MODULAR TYPE ZMAC ADVANCED BORING HEAD

NIKKEN

ZMAC-V Triangular Insert type head

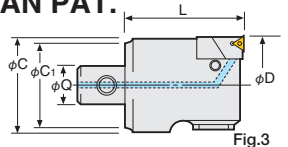
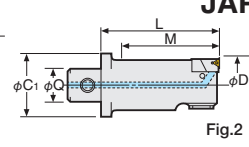
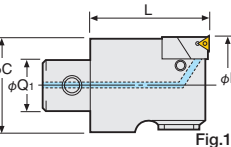

JAPAN PAT.

Head No.	Boring Range D	Boring Depth M	Coupling Dia Q	Remarks					Weight (Kg)
				C	C1	Unit No.	Insert No.	Fig.	
12-ZMAC 16- 45V	15.9~20.2	38	12	15	24	M 2HZ- 16V	3MP-C,B	2	0.4
12-ZMAC 16- 55V		48							0.4
9-ZMAC 20- 40V	19.8~25.2	40	9	19	-	M 2HZ- 20V	4MP-C,B	1	0.4
12-ZMAC 25- 40V	24.8~32.2		12	24		M 3HZ- 25V			0.5
16-ZMAC 32- 55V	31.8~42.2	55	16	31	-	M 4HZ- 32V	6MP-C,B	1	0.7
20-ZMAC 42- 70V	41.8~55.2		20	40		M 5HZ- 42V			1.1
26-ZMAC 55- 70V	54.8~70.2	70	26	53	-	M 5HZ- 55V	1.2		

★MIN. dial readout: ZMAC25-V and smaller is 0.02mm on dia. ZMAC32-V and larger is 0.01mm on dia. ★The above boring ranges are based on heads with Nose/R 0.2 insert.
★"C" grade (Coated) insert for Steel, Stainless & Cast Iron is supplied as Standard with the head (Smooth boring & Long tool-life). ☞ P.21
Please refer NC TOTAL TOOLING SYSTEM for cutting condition. We would recommend "B" grade (CBN) insert for Hardened Steel & High Speed boring of Cast Iron.
★Centre Through Coolant function is available as standard.
★Code No. of the set with SP26 stepped spacer is Q26-Coupling Dia.-ZMAC○-LengthV e.g. Q26-20-ZMAC42-100V

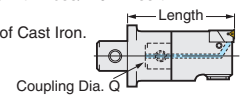

MODULAR TYPE ZMAC& ADVANCED BORING HEAD

NIKKEN

ZMAC&-V Triangular Insert type head

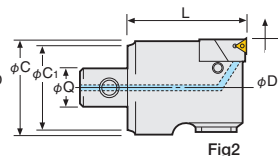
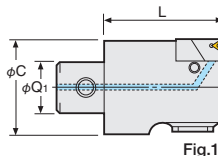

JAPAN PAT.

For High Speed Boring
Deep Hole Boring

Head No.	Boring Range D	Boring Depth M	Coupling Dia Q	Remarks					Weight (Kg)
				C	C1	Unit No.	Insert No.	Fig.	
12-ZMAC 25- 40AAV	24.8~32.2	40	12	24	-	M 3HZ- 25V	3MP-C,B	1	0.4
16-ZMAC 32- 55AAV	31.8~42.2					M 4HZ- 32V			4MP-C,B
20-ZMAC 42- 70AAV	41.8~55.2	70	20	40	-	M 5HZ- 42V	6MP-C,B	1	0.8
26-ZMAC 55- 70AAV	54.8~70.2		26	53		M 5HZ- 55V			0.7

★MIN. dial readout: ZMAC25-AAV and smaller is 0.02mm on dia. ZMAC32-AAV and larger is 0.01mm on dia. ★The above boring ranges are based on heads with Nose/R 0.2 insert.
★"C" grade (Coated) insert for Steel, Stainless & Cast Iron is supplied as Standard with the head (Smooth boring & Long tool-life). ☞ P.21
Please refer NC TOTAL TOOLING SYSTEM for cutting condition. We would recommend "B" grade (CBN) insert for Hardened Steel & High Speed boring of Cast Iron.
★Centre Through Coolant function is available as standard.
★Code No. of the set with SP26 stepped spacer is Q26-Coupling Dia.-ZMAC○-LengthAAV e.g. Q26-20-ZMAC42-100AAV

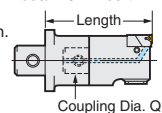

BASE HOLDER for MODULAR TYPE (BT Shank) **NIKKEN**



Q

Code No.	L	H	Coupling Dia Q
BT30-Q 9-50	50	20	9
-Q12-65	65	40	12
-Q16-50	50	25	16
-Q20-50	50	26	20
-Q26-40	40	18	26

★All base holders have a centre through tool coolant hole. ★The coupling screw & wrench are supplied as standard.
★Also available for BT flange contact spindle (NBT30). Example NBT30-Q9-50 ★Please refer to P.22 as for pull studs.

2LOCK MAJOR DREAM HOLDER BASE HOLDER for MODULAR TYPE **NIKKEN**



MDQ

Photo shows with A1 spacer and ZMAC α -V head.

Code No.	L	H	Coupling Dia Q
NBT30-MDQ26-60	60	37.5	0

★All base holders are used for centre through tool coolant. ★Coupling bolt and wrench are supplied as standard.
★ZMAC α -V head is recommended to use with the MAJOR DREAM base holder for anti-vibration.
★Please refer to P.22 as for pull studs.

SPACER for MODULAR TYPE **NIKKEN**

Extension Spacer



SP

Spacer for Modular Type(Extension Spacer)

Code No.	Coupling Dia Q	Coupling Dia Q ₁	Length L
SP 9- 9-30,45	9	9	30,45
-12-12-30,45,60	12	12	30,45,60
-16-16-30,45,60	16	16	30,45,60
-20-20-45,60	20	20	45,60
-26-26-60,90	26	26	60,90

Stepped Spacer



SP

Spacer for Modular Type(Stepped Spacer)

Code No.	Coupling Dia Q	Coupling Dia Q ₁	Length L	Boring Range D
SP12- 9-45	12	9	45	33
SP16- 9-45		9	45	33
-12-60	16	12	60	48
SP20- 9-45		9	45	33
-12-60	20	12	60	47
-16-60,90		16	60,90	47,77
SP26- 9-30,45		9	30,45	15,30
-12-30,60	26	12	30,60	15,15
-16-30,60, 90		16	30,60,90	15,45,75
-20-30,60,100		20	30,60,100	18,48,88

A1 Spacer for Deep Hole



SP

Spacer for Modular Type(A1 Spacer for Deep Hole)

Code No.	Coupling Dia Q	Coupling Dia Q ₁	Length L	Boring Range D
SP26- 9- 85-A1	26	9	85	70
-12-115-A1		12	115	100
-16-140-A1		16	140	125
-20-180-A1		20	180	165
-26-190-90		26	190	190

★All base holders have a centre through tool coolant hole. ★The coupling screw & wrench are supplied as standard.

NIKKEN INSERT TIP (EXCLUSIVE FOR BORING ARBOR)



Material	Steel	Stainless Steel	Cast Iron	Coated Cermet	Coated Carbide M	Coated Carbide K
		●	●	●	●	●

For the Boring of Large Diameter and Short Depth, the use of insert with large nose radius is recommended. The smaller nose radius inserts are ideal for smaller diameter boring or finishing operation.

Applicable Arbor	Dimension	Code No.	Grade	Material NOSE R	C		
					PV720	AC630M	AC410K
RAC25E		CC07-○4	0.4		●	●	
		CC07-○8	0.8		●	●	
RAC32E		CC08-○4	0.4		●	●	
		CC08-○8	0.8		●	●	
RAC43E, RAC53E, RAC70E		CC12-○4	0.4		●	●	
		CC12-○8	0.8		●	●	

Material	Steel	Stainless Steel	Cast Iron	Aluminium	High Speed finish for Cast Iron	Hardened Steel	High Speed finish for Aluminium
	●	●	●				
	●	●					
	●			●	●		
						●	
						●	
							●

For the Boring of Large Diameter and Short Depth, the use of insert with large nose radius is recommended. The smaller nose radius inserts are ideal for smaller diameter boring or finishing operation.

Applicable Arbor	Dimension	Code No.	Grade	Material NOSE R	Coated Cermet	Cermet (w/o coating)	Carbide P	Carbide K	CBN	Diamond	
					C	T	E	F-NB*2 w/o breaker	F	B	D
					PV720	T1500Z	NS9530	TN90	ST10P	H1	KBN510
ZMAC16-V, ZMAC20-V, ZMAC25-V		3MP-○2	0.2		●	●	●	●*2	●	●	
		3MP-○4	0.4		●				●	●	
ZMAC32-V		4MP-○2	0.2	●	●	●	●	●*2	●	●	
		4MP-○4	0.4	●	●			●*2	●	●	
ZMAC42-V, ZMAC55-V		6MP-○2	0.2	●	●	●	●	●*2	●	●*4	
		6MP-○4	0.4	●	●	●	●	●*2	●	●*4	
		6MP-○8	0.8	●	●	●	●	●*2	●	●*4	

- ★ Minimum quantity of CBN and Diamond: 1pcs, All other insert tip: 10pcs
- ★ *2 "-NB" (w/o breaker) is recommended for cast iron.
- ★ *3 Hole diameter of 6MP is φ2.8mm. M2562D (Optional tip clamp bolt) is required for the ISO standard insert tip with the hole diameter of φ3.3~φ3.5mm.
- ★ *4 M2562D is necessary for 6MP-D (Diamond), because of the hole diameter is different.
- ★ The ISO code No. surrounded with () is the Nikken original insert tip.

Code No. of ISO standard Insert Tip

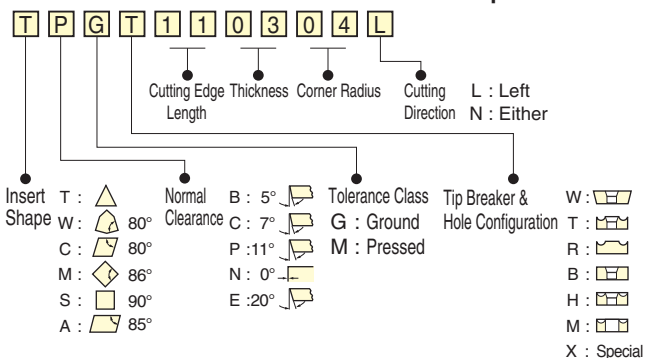

Please add the grade indication into ○, and add the insert tip material indication at the end off the Code No. e.g. 6MP-C4 (PV720), 6MP-F4-NB (H1)

FACE MILL ARBOR

NIKKEN

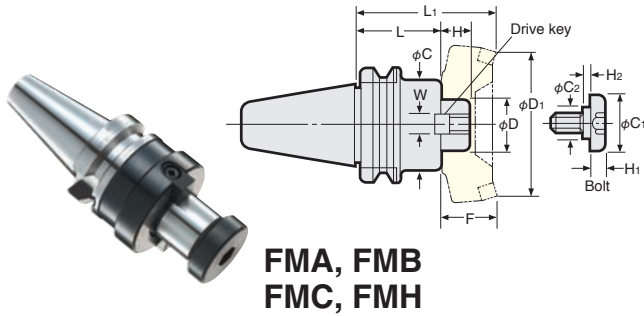

Code No.	D	L	H	C	C1	W	Weight (kg)
BT30-FMA25.4-45	25.4	45	22	50	33	9.5	0.9
-FMB25.4-45	25.4	45	26	80	33	9.5	1.2
-FMB27-45	27	45	26	80	33	12	1.2
-FMC25.4-45	25.4	45	20	60	18	9.4	1
-FMC22-40	22	40	18	45	16	10	0.8
-FMH16-37-35	16	35	17	37	20	8	0.6
-FMH22-47-45	22	45	18	47	16	10	0.8

★ Drive keys, L-Wrench & Bolt are supplied as standard. ★ Please refer to P.22 as for pull studs.
 ★ Above weight is for Arbor only. (Not include Face Mill Cutter)
 ★ All series have through-centre. ★ FMH is available for cutters with oil hole.
 ★ Also available for BT flange contact spindle (NBT30). Example NBT30-FMA25.4-45

PULL STUD

NIKKEN

Centre Through Coolant	Code No.	Fig.
No	PS-17	1
Yes	PS-130E	2



Fig.1

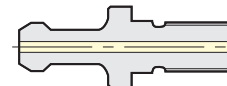

Fig.2

Sample : Tool Layout for BROTHER SPEEDIO

Tool layout example for Brother Industries SPEEDIO

Machine specifications:
 Flange contact NBT30 /
 with centre through coolant

No.	Product name	Code No.	Qty.	Remarks
1	Slim Chuck	NBT30-SK6C-60	4	Gripping diameter:0.7~6.0
2	Slim Chuck Collet (Common to Slim Chuck and Major Dream Holder)	SK6-3	2	Gripping diameter:2.8~3.0
3		SK6-4	2	Gripping diameter:3.5~4.0
4		SK6-6	2	Gripping diameter:5.5~6.0
5		Spanner	SKL-6W	1
6	Slim Chuck	NBT30-SK13C-75	8	Gripping diameter:2.75~13.0
7	Major Dream Holder	NBT30-MDSK13-75	4	Damping mechanism reduces chatter, suitable for end-mill machining.
8	Slim Chuck Collet (Common to Slim Chuck and Major Dream Holder)	SK13-4	3	Gripping diameter:3.5~4.0, also for M3 tapping
9		SK13-5	1	Gripping diameter:4.5~5.0, also for M4 tapping
10		SK13-6	3	Gripping diameter:5.5~6.0, also for M6 tapping
11		SK13-6.5	1	Gripping diameter:6.0~6.5, also for M8 tapping
12		SK13-7	1	Gripping diameter:6.5~7.0, also for M10 tapping
13		SK13-8	3	Gripping diameter:7.5~8.0
14		SK13-8.5	1	Gripping diameter:8.0~8.5, also for M12 tapping
15		SK13-10	3	Gripping diameter:9.5~10.0
16		SK13-12	3	Gripping diameter:11.5~12.0
17	Spanner	9HC12A	1	SK13 tightening spanner
18	GH Handle	GH12	1	SK13 tightening GH Handle
19	Mini-Mini Chuck	NBT30-MMC12C-105-AA	2	Suitable for small diameter end milling and drilling
20	VMK-J Collet (Coolant collet for Mini-Mini Chuck)	VMK12-4J	1	Gripping diameter: 3.0 / for jet coolant
21		VMK12-6J	1	Gripping diameter: 4.0 / for jet coolant
22		VMK12-8J	1	Gripping diameter: 6.0 / for jet coolant
23	Milling Chuck	NBT30-C20-75	2	Gripping diameter:2.0~20.0
24	Spanner	9HC22	1	C20 tightening spanner
25	Universal Micro Touch	BT30-UMT150	1	Compact type for BT 30 machines
26	Height Presetter	HP-50K	1	Continuity detection type
27	Pull Stud	PS-130E	21	With hole type
28	Tool Clamper	TCL-46GH	1	

*The above layout is based on flange contact NBT30 specification. BT30 specification is also available. This is the relevant page of the NC General Catalogue.

TURNING TOOLING SYSTEM for M200Xd1 / M300Xd1 (Boring bar holder)

NIKKEN

Boring bar holder (φ20): For Internal boring

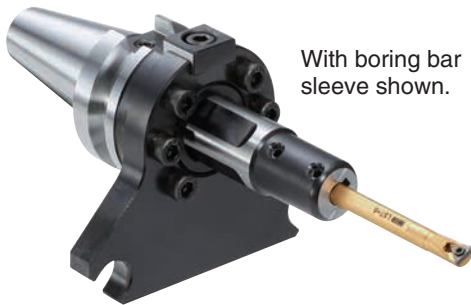

With boring bar sleeve shown.

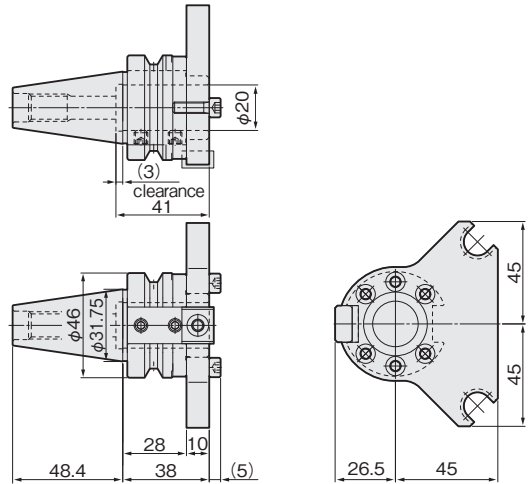
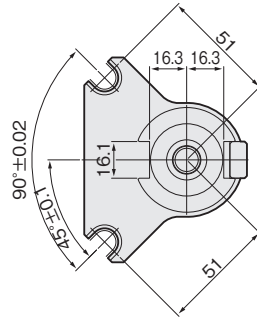

Cutting Direction	Code No.
Neutral	BT30-BHC20-30

- ★Coolant through spindle (CTS) can be used.
- ★With boring bar sleeve (sold separately) φ6, φ8, φ10, φ12, φ16 boring bars can be used.
- ★Also available for BT flange contact spindle (NBT30). Example NBT30-BHC20-30

TURNING TOOLING SYSTEM for M200Xd1 / M300Xd1 (External turning tool holder)

NIKKEN

External turning tool holder (□20): 180° Type / for External turning · Facing

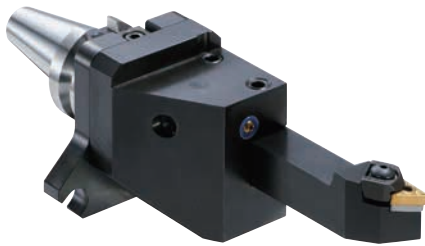

Right hand tool holder shown.

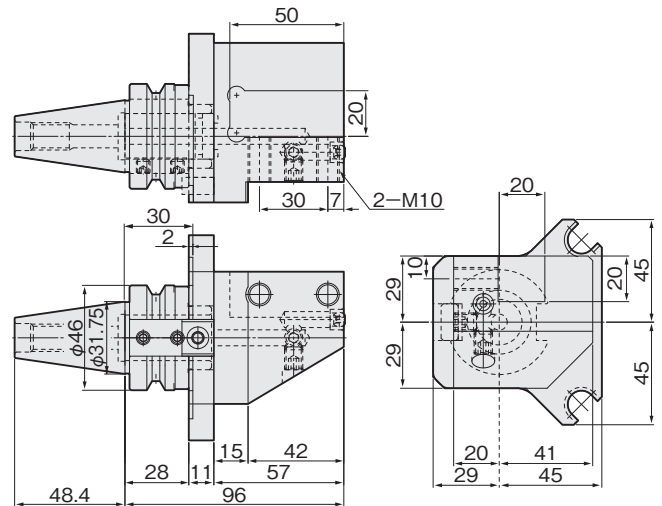
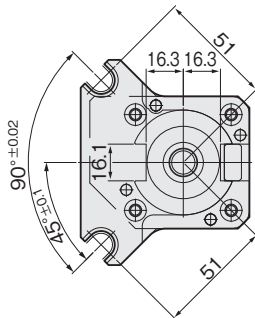

Cutting Direction	Code No.
Left	BT30-BHS20-96-X2-L
Right	BT30-BHS20-96-X2-R

- ★Coolant through spindle (CTS) can be used.
- ★The coolant discharge direction can be adjusted by means of a variable nozzle.
- ★Also available for BT flange contact spindle (NBT30). Example NBT30-BHS20-96-X2-L

External turning tool holder (□20): 90° Type / for External turning



Left hand tool holder shown.

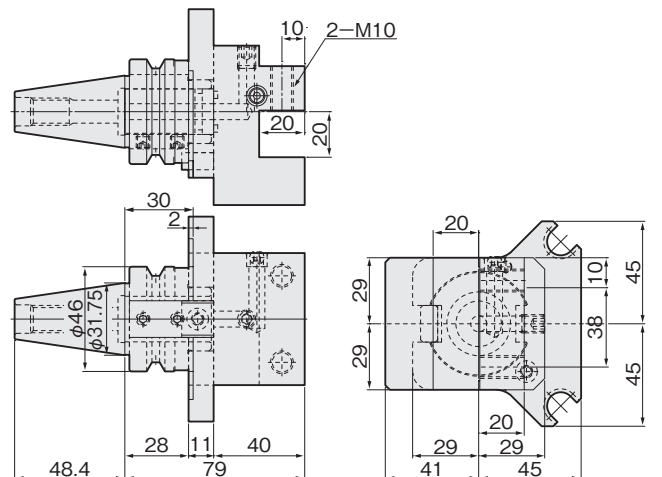
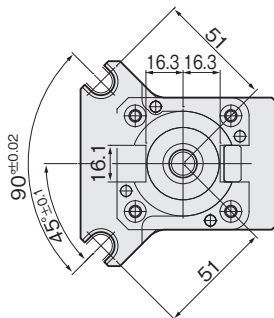

Cutting Direction	Code No.
Left	BT30-BHSH20-79-X2-L
Right	BT30-BHSH20-79-X2-R

- ★Coolant through spindle (CTS) can be used.
- ★The coolant discharge direction can be adjusted by means of a variable nozzle.
- ★Also available for BT flange contact spindle (NBT30). Example NBT30-BHSH20-79-X2-L

Boring bar sleeve for BT30-BHC20-30 ($\phi 6, \phi 8, \phi 10, \phi 12, \phi 16$)



Standard type: suitable for boring bars without oil holes
Coolant through type: suitable for boring bars with oil holes..

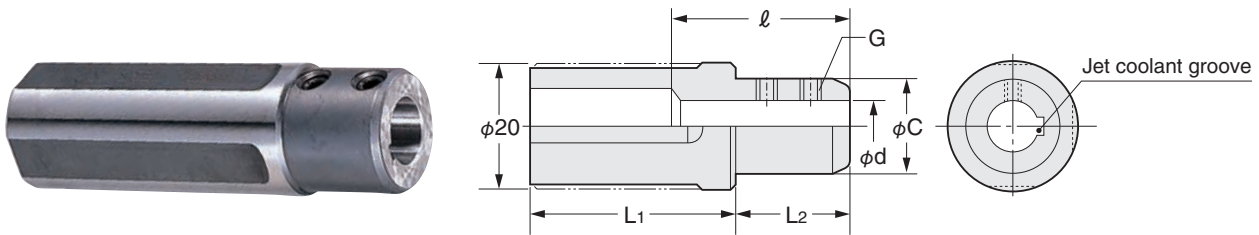

Code No.	d	C	L1	L2	l	G
LEA20S- 6 (C)	6	18	26	41	32~67	9SLG5P0.5-5
8 (C)	8	19.5			36~67	9SLG6P0.75-6
10 (C)	10	27	41~67		9SLG6P0.75-5	
12 (C)	12	24.5	45~67		M6-8L	
16 (C)	16		30		9SLG6P0.75-5	

★The coolant is discharged through a jet coolant groove in the bore of the boring bar sleeve.

BT15 TOOL HOLDER



SLIM CHUCK



BT15BR

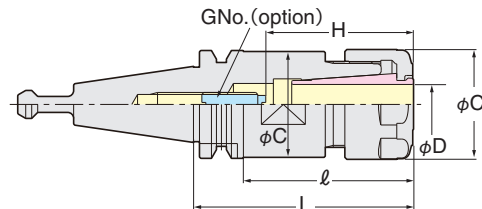

BT15 Shank

TAPER	Code No.	D	L	l	C	H	G No. (option)	Weighe(kg)	SK Collet
No.15	BT15BR-SK 6- 40	0.7 ~ 6.0	40	26	19.5	21~35	SKG- 8- 18L	0.10	SK 6
	- 55		55	39				0.14	
	- 65		65	49				0.15	
	-SK10- 40	0.9~10.0	40	26	27.5	30~37	SKG- 6L	0.14	SK10
	- 55		55	41				0.20	

★BT15BR is the solid tool integrated with pull stud for BROTHER.
★Please refer to P26,27 for SLIM CHUCK COLLET



BROTHER SPEEDIO Deburring Center DG-1 is a machine with BT15 spindle. We have prepared BT15 tool holders exclusively for BROTHER, so please order them.

NIKKEN KOSAKUSHO WORKS, LTD. OSAKA, JAPAN.

5-1, 1-chome, Minamishinden, Daito-shi, Osaka-fu, Japan. Telephone : 072-869-5820 Telefax : 072-869-6220

U.S.A CA, CT, IL, NC, TX, WA	LYNDEX-NIKKEN Inc 1468 Armour Boulevard, Mundelein, ILLINOIS 60060 Tel.+1-847-367-4800 Fax.+1-847-367-4815	P.R.CHINA	SHANGHAI ZHONG YAN TRADING CO., LTD. Building 1/f, #54, No.1089 Qinzhou Rd. (N), Shanghai, China Tel.+86-(0)-216210-2506 Fax.+86-(0)-216210-2083
MEXICO (From 2014.09)	HERRAMIENTAS LYNDEX-NIKKEN S.A.de C.V. Av. Hercules #401-13, Fracc. Poligono 3 Santa Rosa Jauregui, Queretaro 76220 Tel.+52-55-8421-8421	SINGAPORE	NIKKEN KOSAKUSHO ASIA PTE, LTD. 186,Woodlands Industrial Park E5 #04-01 M Singapore 757515 Tel.+65-6362-7980 Fax.+65-6362-7980
FRANCE	PROCOMO-NIKKEN S.A.S 6, avenue du 1er Mai-Z.A.E.Les Glaises 91127 Palaiseau Cedex Tel.+33-(0)-1-69.19.17.35 Fax.+33-(0)-1-69.30.64.68	THAILAND	SIAM NIKKEN Co., LTD. 127 Moo5 Gauwungsai-Bangturie Road Tambon Tanokkard Ampher Muangnakhonpathom Nakhonpathom 73000 Thailand Tel.+66(02)178-0503 Fax.+66(02)178-0504
UK	NIKKEN KOSAKUSHO EUROPE LTD. Advanced Manufacturing Park, Brindley Way, Rotherham S60 5FS Tel.+44-(0)-1709-366306 Fax.+44-(0)-1709-376683	INDONESIA	PT.NIKKEN KOSAKUSHO INDONESIA JALAN BIZPARK 3 JABABEKA INNOVATION CENTER A NO.16, KEL.MEKARMUkti, KEC. CIKARANG UTARA, KAB. BEKASI PROP. JAWA BARAT TEL:+62-(0)21-5702071 MAIL:zefry.i@nikken-kosakusho.co.jp
GERMANY	NIKKEN DEUTSCHLAND GMBH CARL-ZEISS-STRASSE 11 NEU-ULM 89231 Tel.+49-731-963397-0 Fax.+49-731-963397-60		http://www.nikken-kosakusho.co.jp/en e-mail : export@nikken-kosakusho.co.jp
ITALY	VEGA INTERNATIONAL TOOLS S.P.A Via Asti N° 9 10026-Santena(TORINO) Tel.+39-011-9497911 Fax.+39-011-9456380		■Please give your order to the following agent.
SCANDINAVIA SWEDEN	NIKKEN SCANDINAVIA AB Malmövägen 14 331 42 Värnamo Sweden Tel.+46-(0)-303-440-600 Fax.+46-(0)-303-58177		
SPAIN & PORTUGAL	UTILLAJES OLASA,S.L. C/ Aienas 3 - Nave 22 Pol. 27 (Mateo Gaina) 20014 Donostia - San Sebastián [Gipuzkoa] Tel.+34-(0)-943-107177 CUTTING TOOLS S.L. Tel.+34-(0)-902-820090 Fax.+34-(0)-902-820099		
TURKEY	NIKKEN KESICI TAKIMLAR SAN. VE ULUSLARARASI TIC. A. S E5 Uzeri Kucukyali Yanyol Irmak Sok. Kucukyali Sanayi Sitesi A Blok No:5 Maltepe 34852 Istanbul Tel.+90-(0)-216-518-1010 Fax.+90-(0)-216-366-1414		
KOREA	KOREA NIKKEN LTD. 90B-11L, Namdong Industrial Complex, 170, Namdong-Daero, Namdong-Gu, Incheon, Korea 405-819 Tel.+82-(0)-32-763-4461 Fax.+82-(0)-32-763-4464		

D.SK.2

●Specifications are subject to change without notice.

●The specification are subject to be changed without prior notice.

●The photo. of the machine is permitted to use from BROTHER. The content in this catalogue is published responsible by NIKKEN.