

Specially designed CNC Rotary Table
for ISO 30 class machine

CNC ROTARY TABLE

+2 AXIS

5AX CNC ROTARY TABLE
5AX-100

ULTRA Compact
ULTRA Light 84kg

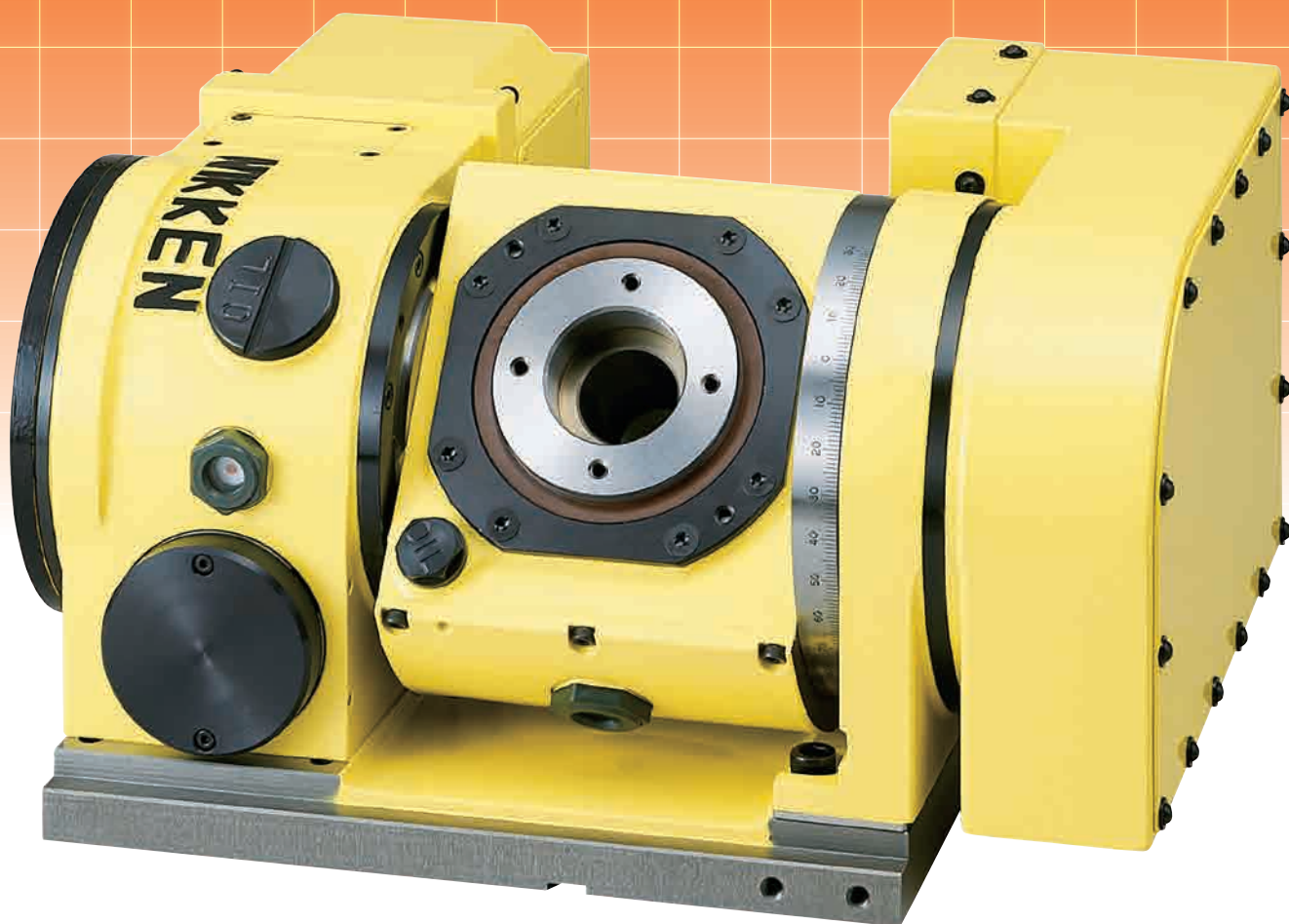

NIKKEN

NIKKEN KOSAKUSHO WORKS, LTD.

5-1, 1-chome, Minamishinden, Daito-shi, Osaka-fu, Japan

Tel:+81-(0)72-869-5820

Fax:+81-(0)72-869-6220

CNC TILTING ROTARY TABLE 5AX-100



Smallest-sized 5AX rotary table in history. Specially designed for ISO 30 class machine. It is allowed to maximize the machining area, comparing to the other conventional models.

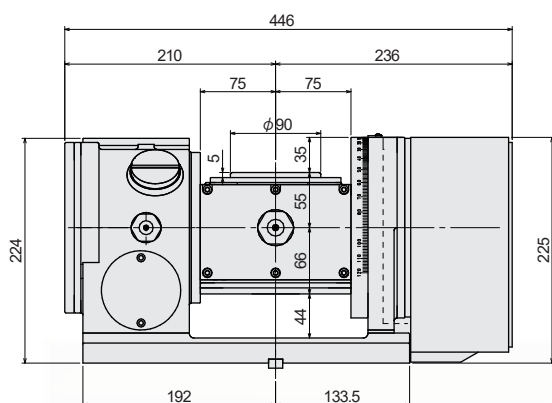
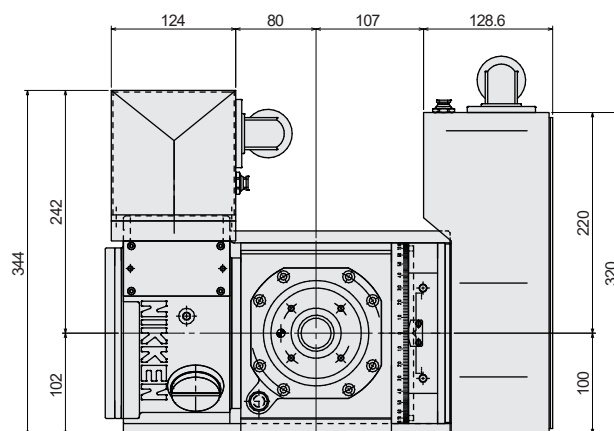

*Dimension : with AA21 controller

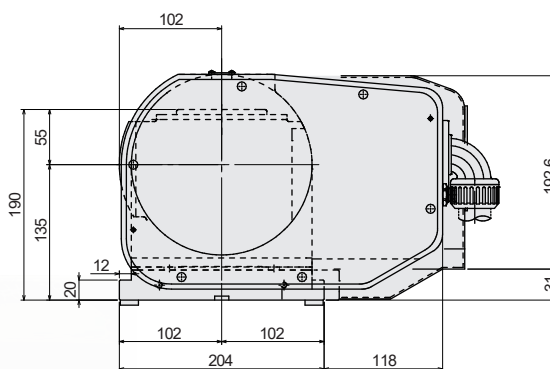

SPECIFICATIONS

FACE PLATE DIA.		$\phi 90$ mm
CLAMPING SYSTEM	rotating :	Pneumatic
	tilting :	Air-hydraulic
CLAMPING TORQUE	rotating :	205 Nm
	tilting :	410 Nm
ROTATION SPEED	rotating :	44.4 min ⁻¹
	tilting :	22.2 min ⁻¹
TOTAL REDUCTION RATIO	rotating :	1/45
	tilting :	1/90
DRIVING TORQUE		18 Nm
INDEXING ACCURACY	rotating :	± 30 sec
	tilting :	60 sec
REPEATABILITY	rotating :	4 sec
	tilting :	± 6 sec
MAX. LOAD	0-30°	40 kg
	30-90°	20 kg
NET WEIGHT		84 kg

Center hole

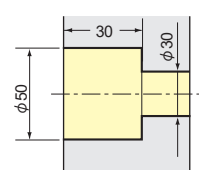

Interference area of work-piece (when tilting)

