

NEW

Challenge to Micro-Balance

Balance-able Shrink Fit Holder

To adjust the unbalance is possible after chucking the cutting tools by the special screws.

HSK100



**Super High Speed
Operation**

HSK63



■ All tools are pre-balanced except bundled parts

HSK63A	30,000RPM	G2.5
HSK80F/100A	20,000RPM	G2.5
NBT40/50	20,000RPM	G2.5



Special unbalance adjusting screw

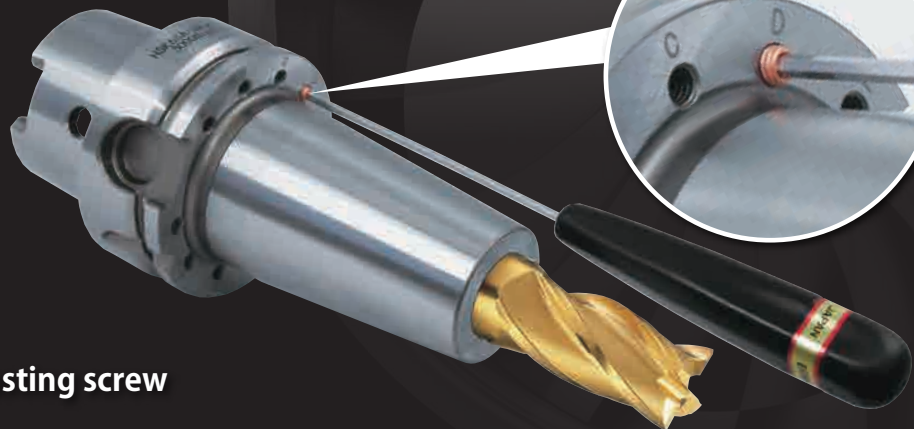

NIKKEN

NIKKEN KOSAKUSHO WORKS, LTD.
5-1, 1-chome, Minamishinden, Daito-shi, Osaka-fu, Japan

Web: www.nikken-kosakusho.co.jp/en
Tel: +81-(0)72-869-5820 Fax: +81-(0)72-869-6220
e-mail: export@nikken-kosakusho.co.jp

Technical Specifications

HSK

(mm)

Taper	Code No.	ϕD	L	L1	L2	ϕC	$\phi C1$	Back-up Screw
HSK63A	HSK 63A-SF12- 90B-LY	12	90	36	47	24	32	M10
	HSK 63A-SF16- 95B-LY	16	95	39	50	27	34	M12
	HSK 63A-SF20-100B-LY	20	100	41	52	33	42	M16
	HSK 63A-SF25-115B-LY	25	115	47	58	44	53	M16
HSK80F	HSK 80F-SF12- 80B-LY	12	80	36	47	24	31	M 8
	HSK 80F-SF16- 80B-LY	16	80	39	50	27	34	M 8
	HSK 80F-SF20- 90B-LY	20	90	41	52	33	42	M 8
	HSK 80F-SF25-100B-LY	25	100	47	58	44	53	M 8
HSK100A	HSK100A-SF12- 95B-LY	12	95	36	47	24	32	M10
	HSK100A-SF12-160B-LY	12	160	36	47	24	32	M10
	HSK100A-SF16-100B-LY	16	100	39	50	27	34	M12
	HSK100A-SF16-160B-LY	16	160	39	50	27	34	M12
	HSK100A-SF20-105B-LY	20	105	41	52	33	42	M16
	HSK100A-SF20-160B-LY	20	160	41	52	33	42	M16
	HSK100A-SF25-115B-LY	25	115	47	58	44	53	M16
	HSK100A-SF25-160B-LY	25	160	47	58	44	53	M16

NBT (Face contact)

(mm)

Taper	Code No.	ϕD	L	L1	L2	ϕC	$\phi C1$	Back-up Screw
NBT40	NBT40-SF12- 90B-LY	12	90	36	47	24	32	M10
	NBT40-SF16- 90B-LY	16	90	39	50	27	34	M12
	NBT40-SF20- 90B-LY	20	90	41	52	33	41	M16
	NBT40-SF25-100B-LY	25	100	47	58	44	52	M16
NBT50	NBT50-SF12-100B-LY	12	100	36	47	24	32	M10
	NBT50-SF12-160B-LY	12	160	36	47	24	32	M10
	NBT50-SF16-100B-LY	16	100	39	50	27	34	M12
	NBT50-SF16-160B-LY	16	160	39	50	27	34	M12
	NBT50-SF20-100B-LY	20	100	41	52	33	41	M16
	NBT50-SF20-160B-LY	20	160	41	52	33	42	M16
	NBT50-SF25-100B-LY	25	100	47	58	44	52	M16
	NBT50-SF25-160B-LY	25	160	47	58	44	53	M16

HSK

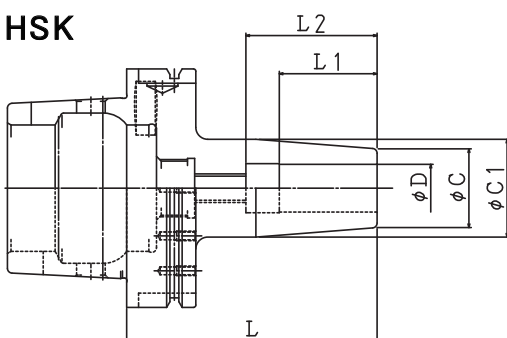

NBT

