

# THREE ANGLE CLAMPER NEW

**NIKKEN**



## Exchangeable Adapter

Please select suitable one by the table below.

Clamp Ring

## TOOL CLAMPER MAIN BODY

\*Check the direction of rotation of clamp ring to make sure that there will be no interference between the position of the clamper and the cutter or pull stud.

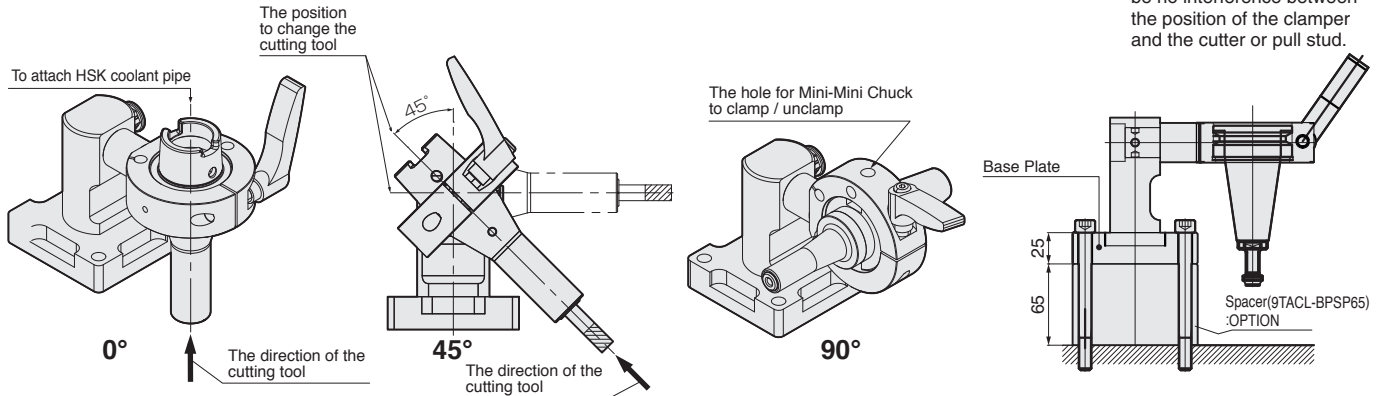

Clamper Code No.	BT40	BT50	IT40	CAT40	NC5-63	NC5-100	HSK63	HSK100	C6 (special)
TACL-B40H63	○	—	—	—	○	—	○	—	○
TACL-B50H100	—	○	—	—	—	○	—	○	—
TACL-ICAT40	—	—	○	○	—	—	—	—	—

## Exchangeable adapter

TACL-B40H63 Suitabele Clamper	Adaptation shank
9TACL63D-B30N46	BT30 NC5-46
9TACL63D-HSK50	HSK50 C5*1
9TACL63D-HSK40	HSK40 C4
9TACL63D-HSK32	HSK32
9TACL63D-HSK25	HSK25

\*1 Length at  $\phi 50$  must be over 25.4mm.

## Replacement adapter for Straight Shank

TACL-B40H63 Suitabele Clamper	Adaptation shank
9TACL63D-S5/8	K5/8CM
9TACL63D-S3/4	K3/4CM ST3/4
9TACL63D-S20	K20CM ST20
9TACL63D-S25	K25CM ST25
9TACL63D-S1	K1CM ST1

# TOOL CLAMPER For GH Handle Type

**NIKKEN**

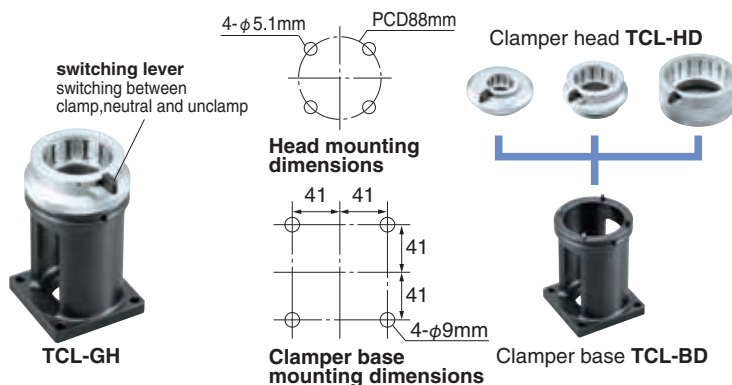

Please use the TCL-GH clamper as a clamper for tools that do not have drive grooves or U grooves, such as the HSK E / F type. Different shanks can be clamped as long as the V-flange diameter is the same.

EX.) TCL-63GH (HSK63A, 63E, 63F, BT40, NC5-63)

The clamper base is common, and various shanks can be supported by exchanging the clamper head.

CLAMPER Code No.	BASE Code No.	HEAD Code No.	SHANK
TCL- 25GH	TCL-BD	TCL- 25HD	HSK 25E
TCL- 32GH		TCL- 32HD	HSK 32E
TCL- 40GH		TCL- 40HD	HSK 40A, 40E
TCL- 46GH		TCL- 46HD	BT30, NC5-46
TCL- 50GH		TCL- 50HD	HSK 50A, 50E
TCL- 63GH		TCL- 63HD	HSK 63A, 63E, 63F, BT40, NC5-63
TCL-100GH		TCL-100HD	HSK100A, BT50, NC5-100

MEASUREMENT