

5AX-800, 5AX-1200



External dimensions depend on the type of the servo motor. Indicated dimensions are in case of FANUC. Please contact us for CAD files (2D:DXF, 3D:PARASOLID).

5AX-800

Powerful double clamping system on both ends of tilting axis.

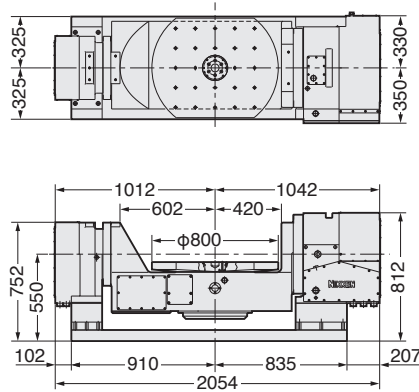
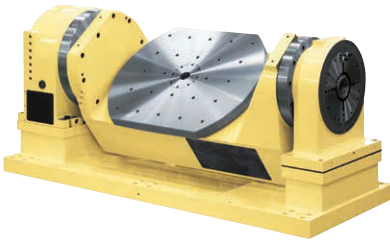

5AX-1200

Powerful double clamping system on both ends of tilting axis.

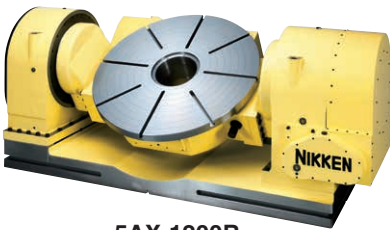

5AX-1200B

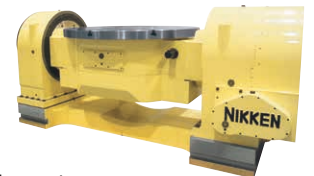
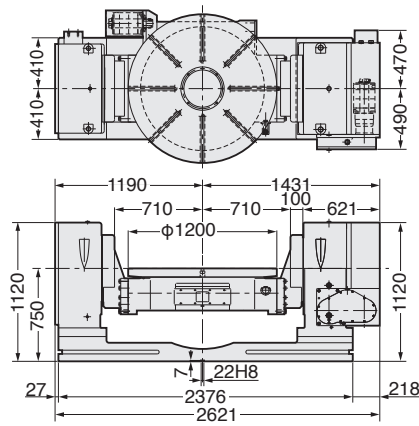

5AX-1200A is also available. The face plate is located above the center of the tilting axis.

The Area of Noninterference in Tilting Position.

Angle	5AX-800	5AX-1200
0° ∩ 45°		
0° ∩ 90°		
0° ∩ 120°		

Counter balance weight can be installed on 5AX-1200A to compensate the unbalancing load as standard.

