

5AX-2MT, 5AX-4MT

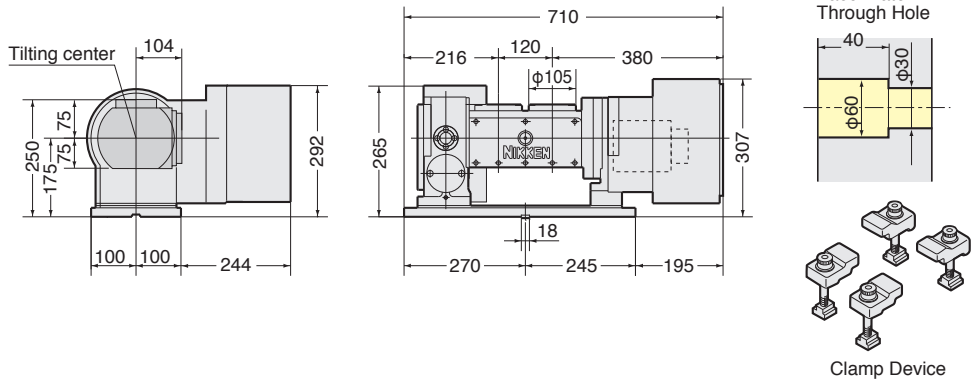

External dimensions depend on the type of the servo motor. Indicated dimensions are in case of FANUC. Please contact us for CAD files (2D:DXF, 3D:PARASOLID).

5AX-2MT-105-120

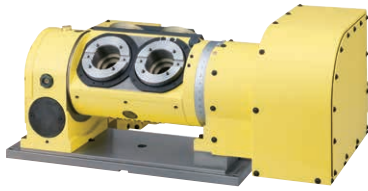

Center height of high column table is 35mm higher than that of standard table.
 MAX. number of ports in rotary joint Standard: 4 ports, High Column: 6 ports
 If you need a knock hole for positioning or a key way on the table surface, please contact us.

5AX-4MT-105-120

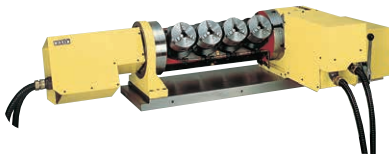

4" Power chuck in photo is optional.

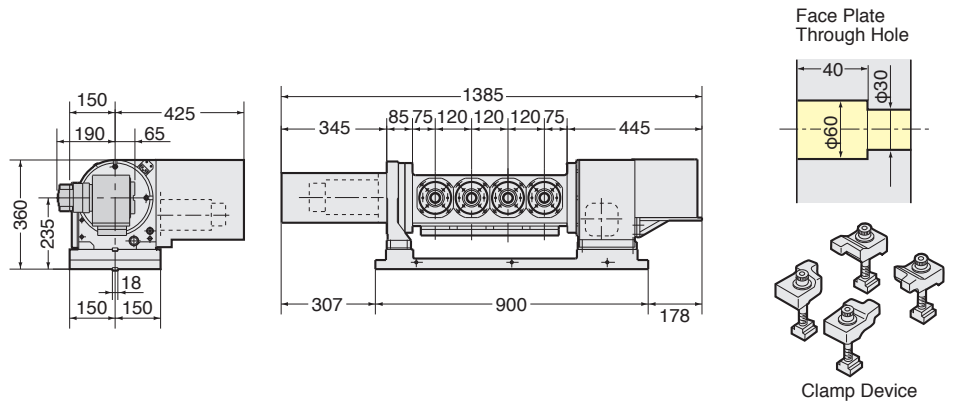

MAX. 6 port rotary joint can be installed on standard type as an option.
 If you need a knock hole for positioning or a key way on the table surface, please contact us.

Multi-Spindle Tilting Rotary Table

For Multi-Spindle Tilting Rotary Table, please contact us to know the required faceplate diameters, fixture attachment (e.g. Power Chuck etc), the required spindle pitch, the M/C model and the type of NC.



5AX