

CNC100-2W, 3W, 4W, CNC180-2W, CNC202-2W, CNC260-2W

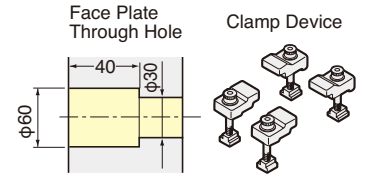

External dimensions depend on the type of the servo motor. Indicated dimensions are in case of FANUC. Please contact us for CAD files (2D:DXF, 3D:PARASOLID).

CNC100-2W

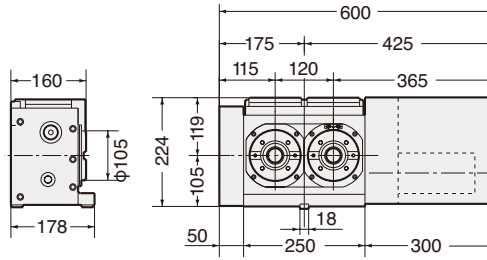

Air purge function is provided inside the motor cover as standard.

CNC100-3W

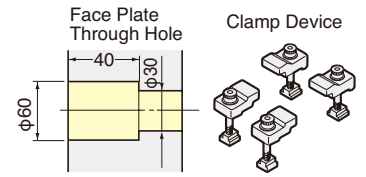
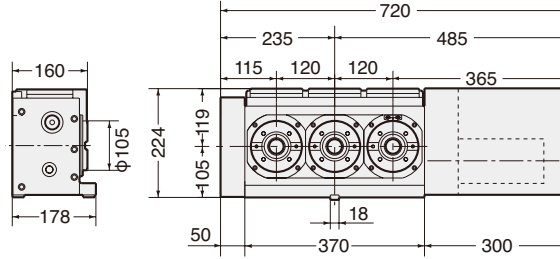

Air purge function is provided inside the motor cover as standard.

CNC100-4W

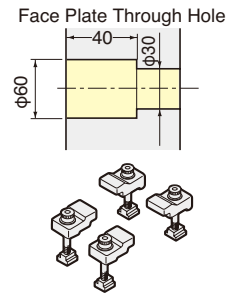
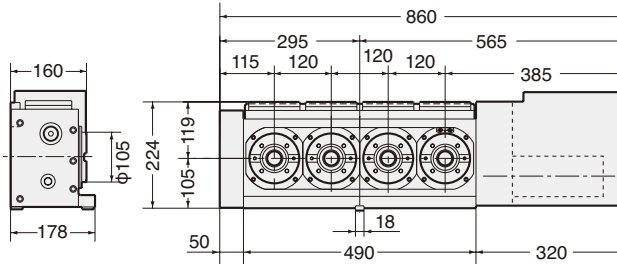

Air purge function is provided inside the motor cover as standard.

CNC180-2W, CNC202-2W

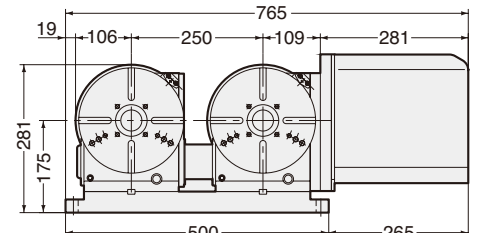
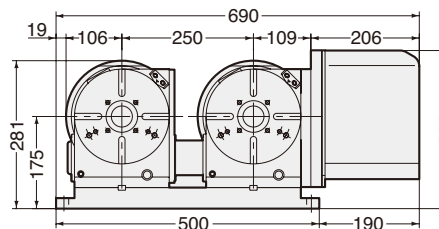

CNC180-2W

CNC202-2W



Air purge function is provided inside the motor cover as standard.

CNC260-2W

Pneumatic Clamping Torque UP 588Nm

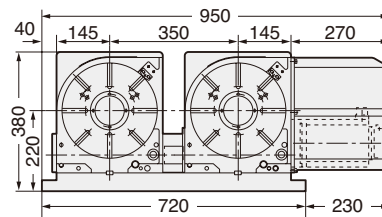
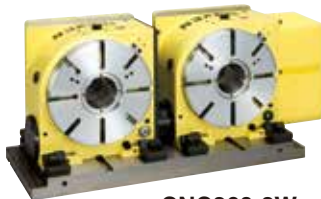

CNC260-2W



For the rotary table with pneumatic clamping, air purge function is provided inside the motor cover as standard.

CNC260-2W-325T

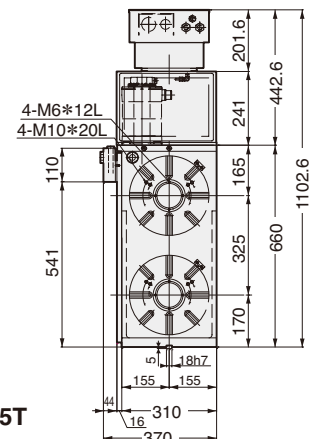

CNC260-2W-325T